



*GeliosPlus*

**GELIOS PLUS 11/13/16/20/24/28 HM  
HERMETIC MONOTERMIC COMBI BOILER**



**INSTALLATION AND USER'S  
OPERATING INSTRUCTIONS**

## CONTENTS

INTRODUCTION .....	1
WARRANTY AND SERVICE .....	1
SYMBOLS .....	1
SAFETY RULES AND WARNINGS .....	2
PRODUCT .....	3
General Features .....	3
Product Notation .....	4
Technical Features .....	4
Electric Circuit Scheme .....	5
PACKAGING .....	6
ASSEMBLY.....	7
Selection of Assembly Point for the Device .....	7
CONNECTIONS.....	8
Issues to be Considered in Funnel Connections.....	10
Hermetic Type Flue Connections .....	11
Gas and Water pipe Connection .....	18
Electric Connection.....	18
Room Thermostat (Optional) .....	19
START-UP AND USAGE.....	21
OPERATION OF DEVICE .....	24
DETERMINATION OF ERRORS & MALFUNCTIONS AND TROUBLESHOOTING.....	28
ASSEMBLY TEMPLATE.....	30
ANNEXES.....	32

## ■ INTRODUCTION

E.C.A. GELIOS PLUS 11/13/16/20/24/28 kW hermetic combi boilers have been designed for efficient, safe and comfortable central heating and domestic hot water requirement.

Detailed explanations regarding technical features of the device, selection of the point of assembly, making the connections (water, gas, flue and electric), maintenance information, determination of possible malfunctions and troubleshooting have been provided in the guide.

Please carefully read the guide in order to benefit from all the features of your device and to use it for a long term without any problems.

Keep all the documents provided by your device in order to refer when required.

## ■ WARRANTY AND SERVICE

- All repairs and annual maintenances should be performed by E.C.A. authorized services. Your device has 2 years' E.C.A. service warranty against all kinds of malfunctions that may arise from material and workmanship provided that it is conformed to instructions and warnings being specified in the assembly and usage guide.
- For the guarantee to be valid, you have to have the date of purchase recorded on the warranty certificate provided by the guide and approved by the place from where you buy the device.
- This E.C.A. product doesn't require repair under normal conditions of use. But in case you need help on any issue, EMAR -the after sales customer services of E.C.A. being available in the whole country- is always at your service.
- The list covering the addresses of our authorized services has been provided additionally.
- The lifetime determined and declared by Ministry of Customs and Trade for the combi boiler devices is 15 years.
- it is in conformity with the EEE regulation.

## ■ SYMBOLS

The following symbols have been placed at required points within the text in order to attract attention to important points relevant to usage and assembly of the device. The meanings of the symbols have been specified below.



**CAUTION:** Specifies that material or insignificant personal damage may arise.

**DANGER:** Specifies that significant personal damage may arise.



• Explanations covering the information that should be considered by the user.



• Indicates the conditions which shouldn't be interfered by the user and which are under the responsibility of authorized service.

## SAFETY RULES AND WARNINGS

### Safety Rules

#### *In case of sensing gas smell;*

- Close the gas valve of the device and the valves of all other devices operating with gas.
  - Close stove, oven etc. devices and shut down their flames.
  - Do not light matches, lighters etc., and put out your cigarette.
  - Ventilate the environment by opening the doors and windows.
  - Do not touch the buttons and plugs of electric appliances.
  - Close the gas valves by the entrance of flat and building.
  - Do not use the phones at environments where gas smell exists.
  - Call your qualified person as soon as possible.
- Do not keep and use inflammable and explosive materials near your device.
  - During cleaning, gas leakage test etc. operations, keep the materials such as water and foam far from electrical connections.
  - Do not close the vents at the environment where your device is available.
  - This appliance can be used by children aged from 8 years and above and persons with reduced physical, sensory or mental capabilities or lack of experience and knowledge if they have been given supervision or instruction concerning use of the appliance in a safe way and understand the hazards involved
  - Children shall not play with the appliance
  - Cleaning and user maintenance shall not be made by children without supervision
  - The device is consist of sheet metals which have sharp edges that may cause injuries. Service operation must be done by only authorized people. Proper personel protective equipments must be used during service operations.

### Installment

- **Connect your device to 230V AC, 50 Hz grounding plug line.**
- Before the assembly of your device, the natural gas, central heating and domestic hot water installations are required to be ready. Natural gas installation should have been designed, approved and realized by an authorized engineering office. The expenses of all these operations belong to the user.

### Assembly

- The assembly of the device should be performed by the authorized installer vendor in accordance with the instructions (selection of place, flue connection etc.) included in the assembly guide and being specified by TSE (Turkish Standards Institute) and authorized gas institutions.
- The device shouldn't be assembled as to directly expose the device to effects of water and detergent vapor etc.
- Any change shouldn't be performed regarding funnel connections without consulting to authorized service.

### Commissioning

- Start-up of the device should be performed by the authorized service. The gas should have been opened by the authorized gas company for the commissioning of the device.
- The conformity controls of the information included in the label such as gas feeding supply pressure (mbar), maximum water pressure it can use (bar) and electrical supply rated voltage (V) with the local supply conditions should be completely performed.
- Following the installation of the device and by the end of start-up, request information from the authorized service regarding the operation and security mechanisms of the device.

### Usage and Maintenance

- Consider the warnings in the assembly and usage guide. Thus, incorrect use and relevant dangers will be prevented.

- The general maintenance of your device should be performed each year by the beginning of the season. Have the maintenance operations performed by E.C.A. authorized services.
- The cleaning of exterior surfaces of the device should be performed just by a damp cloth without using detergent or any chemicals. The use of detergent etc. chemicals may cause corrosion and scratches on your device.

## ■ PRODUCT

### ■ General Features

E.C.A. GELIOS PLUS 11/13/16/20/24/28 kW hermetic combi boilers is for central heating and domestic hot water usage.

It enables saving of place by its design that provides ease of service and maintenance and by its size of 720x400x330. It has a delicate appearance with its round lines and design.

Its control panel has been designed in an ergonomic structure. Its operation functions, central heating circuit and running water temperatures, malfunction status, setting values, water pressure information and current values may be seen over the LCD.

The operation functions and security of the device is ensured over a single center, the 'main board'. The main board controls the gas valve, fan, circulation pump and 3 way valve. Whether there exists flame in burner may be monitored from the sightglass on the front panel or from the LCD display .

The burner has been built from stainless steel material that is resistant to temperature and thermal stress. It operated silent with its special design, and it ensures an efficient and clean combustion as the result of homogenous distribution of gas. In accordance with the burner, a combustion chamber with perfect isolation enabling high efficiency and low gas emission with minimum heat loss has been designed. Due to these features of the burner and combustion chamber, fuel saving is ensured, and also minimum noise level is obtained.

The circulation pump has automatic air relief cock and three cycles, and it is suitable for all the installations. The device has 'pump over-run' feature that prevents thermal accumulation in the installation. After ending of central heating and/or domestic hot water requirement, the circulation pump continues to operate for a specific period by this feature.

High efficiency is obtained by durable copper exchanger that has been designed to prevent thermal shock. Moreover, there is a separate exchanger with steel plate within the device in order to obtain comfortable and efficient domestic hot water.

By the safety systems on your device, the full safety of your device and you has been ensured. These safety systems;

- Flame Out Safety
- Excessive Temperature Safety (105°C)
- Running Water Excessive Heating Safety (71°C)
- Central Heating Circuit Water Excessive Heating Safety (95°C)
- High Water Pressure Safety (3 bar)
- Low Water Pressure Safety (0.8 bar)
- Low Voltage Safety (155VAC)
- Hot Water Accumulation Safety (additional operation of by-pass circuit and pump)
- Freeze Safety (the electrical connection of the device shouldn't be cut for the operation of freeze safety)
- Pump Jamming Safety
- 3 Way Valve Jamming Safety
- Automatic Air Relief Cock
- Expansion Tank

## Product Notation

Notation	Description
GELIOS PLUS 11/13/16/20/24/28 HM	E.C.A. GELIOS PLUS 11/13/16/20/24/28 kW Hermetic Combi Boiler (monothermic model)

**Table 1**

### Technical Features

GELIOS PLUS hermetic combi boilers are under the C Type devices class (TS EN 15502 - 1). C type devices are ones with closed combustion chamber. The fresh air required for combustion is taken from outdoor through flue connection as independent from the environment where the device is assembled, and the arising waste gas is released to outer environment with a different special flue connection.

Technical features for E.C.A. hermetic combi boilers have been provided in Table 2.

Category	GELIOS PLUS 11, 13, 16, 20, 24, HM					28 HM	Unit
	I <sub>2H</sub>						
Type	C <sub>12(X)</sub> , C <sub>32(X)</sub> , *C <sub>42(X)</sub> , *C <sub>52(X)</sub>						
Gas Type	G20 (natural gas)						mbar
Efficiency	90.6					90.7	%
<b>Power</b>							
P Min. heating power (thermal power)	8,2					9,5	kW
P Max. heating power (thermal power)	11,3	13	16	20	23,3	28	kW
Q Thermal Load (min.)	9,2					10,5	kW
Q Thermal Load (max.)	12,8	14,8	17,9	22,3	25,6	30,5	kW
<b>Gas Consumption</b>							
Natural gas (at full power)	1,38	1,58	1,93	2,41	2,76	3,22	m <sup>3</sup> /h
Natural gas (at min. power)	0,96					1,12	m <sup>3</sup> /h
Nox Class	2						
<b>Heating Circuit</b>							
Minimum Water Pressure	0,8						bar
Maximum Water Pressure	3						bar
Maximum Water Temperature	90						°C
Temperature Setting range	30-80						°C
<b>Hot Running Water</b>							
Min. Flow Rate	3						l/min.
Max. Flow Rate Min.	10 (Δt=33,4)					12(Δt=33,4)	l/min.
Water Pressure	0,3						bar
Max. Water Pressure	10						bar
Hot Water Range	35-64						°C
<b>General</b>							
Electric Supply	230V AC-50 Hz						VAC -Hz
Electric Consumption	119						watt
Protection Class	IPx4D						
Expansion Tank	6					8	Liter
Dimension (Hx WxD)	720x400x330						mm
Weight (without packaging)	32					33	kg
Nox Class	2						
<b>Pipe Connections</b>							
CH	3/4						Inch
DHW	1/2						Inch
Gas	3/4						Inch

**Table 2**

In the calculation of gas consumption; for natural gas; Hu = 9,59 kWh/m<sup>3</sup>

\* : If the twin chimney outlet is not available as shown in Figure 14, a twin chimney adapter should be used to install these chimney types.

## Electric Circuit Scheme

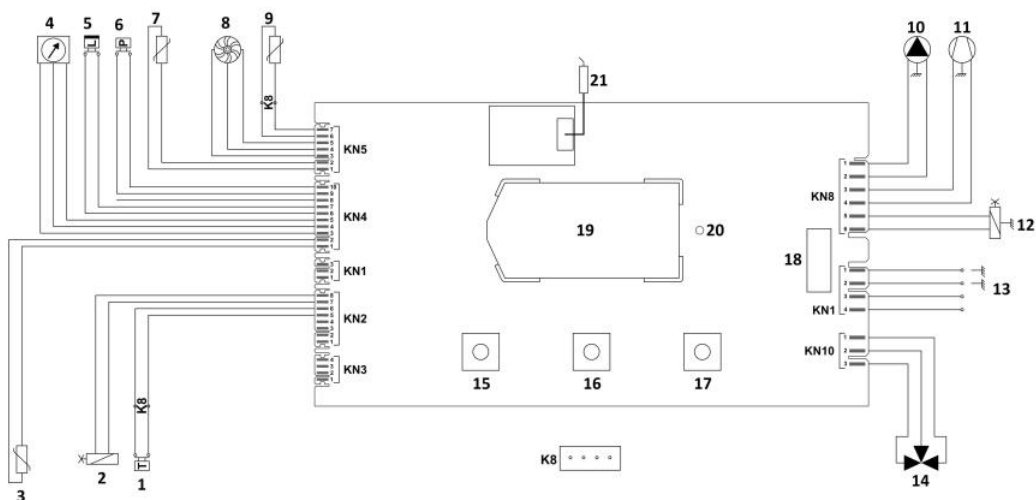

- |                             |   |
|-----------------------------|---|
| 1- ROOM THERMOSTAT (Opt.)   | 12- GAS VALVE                               |
| 2- GAS VALVE MODULATOR      | 13- SUPPLY CABLE                            |
| 3- CH TEMPERATURE SENSOR    | 14- 3 WAY VALVE                             |
| 4- WATER PRESSURE SENSOR    | 15- POTENTIOMETER DHW TEMP.                 |
| 5- LIMIT THERMOSTAT         | 16- POTENTIOMETER CH. TEMP.                 |
| 6- AIR PRESSURE SWITCH      | 17- ON / OFF / RESET / SUMMER / WINTER MODE |
| 7- DHW TEMPERATURE SENSOR   | 18- FUSE                                    |
| 8- TURBINE                  | 19- LCD DISPLAY                             |
| 9- OUTSIDE TEMP. (Optional) | 20- FAILURE LED                             |
| 10- PUMP                    | 21- IGNITION AND IONISATION ELECTRODE       |
| 11- FAN                     |   |

## PACKAGING



**CAUTION:** The warnings of the cardboard packaging should be considered during the transportation and storage of device.

- The device is delivered within a cardboard box as supported with bottom and top styrofoams with a size of 865 x 470 x 405 (HxWxD) (Figure 2).

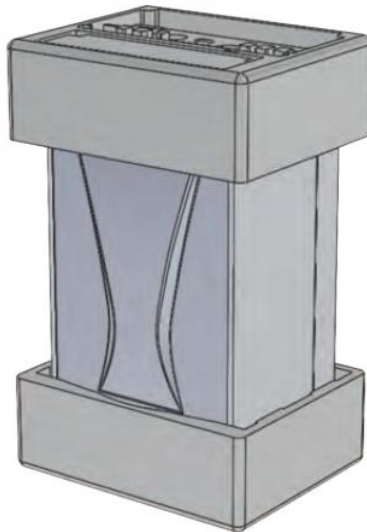

**Figure 2**

→The parts required for the assembly of the device (wall hanger bracket, 5 gaskets for water and gas connections, 3 dowels and lock screws) has been placed on the top styrofoam.

- Assembly bracket
- Central heating water connection pipes (3/4", 2 units)
- Domestic hot water connection pipes (1/2", 2 units)
- Gas inlet pipe (3/4", 1 unit)
- Nipples(1/2", 2 units - 3/4", 3 units)
- 6 units 3/4" gasket and 4 units 1/2" gasket (for water and gas connections)



### Determination of the Location where the Device will be Assembled

- It should be conformed to the rules determined by TSE and authorized gas institutions for the locations where the device may be assembled.

- If the device had been assembled inside a cabinet, the distances required for maintenance and repair should be at least as in Figure 3.

- 2 vents should be made at the bottom and on top of the cabinet, and the vents prevent the heating up of the device by enabling the ventilation of the cabinet. For the vents of the cabinet, that are directly in contact with outdoor air, areas of 220 cm<sup>2</sup> should be left.

As the exterior surface temperature of the device doesn't exceed 85°C at maximum heating power, special protective measure against flammable construction materials and elements is not required.

The following limitations have been imposed by TSE and authorized gas institutions for the locations where the hermetic device will be assembled. Assembly of devices should be performed at

- Stairwells of the buildings,
- Corridors of the buildings which are open for general use,
- On the flue walls,
- At skylights of buildings.

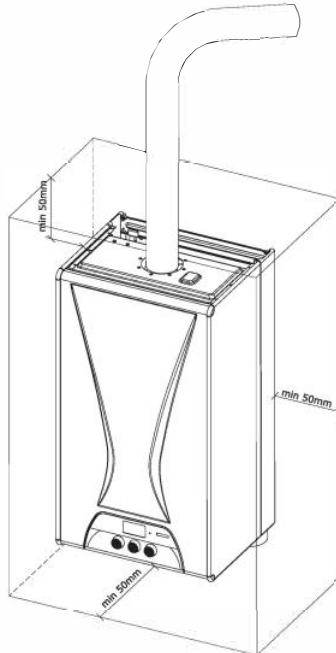

Figure 3



Do not assemble your combi boiler at locations where it will be exposed to direct sunlight. Sunbeams may cause color change on the exterior surface of your device.

**DANGEROUS:** The location where your hermetic device will be assembled and location of hermetic flue outlet should conform to instructions specified by TSE and authorized gas institutions.

## CONNECTIONS

### Issues to be Considered in Flue Connections

In the determination of the location where the device will be assembled, the location of flue outlet is also one of the significant points to be considered. Flue outlets should be directly connected to external environment and to locations where there is air circulation.

Flue outlets shouldn't be connected to;

- Passages and corridors,
- Narrow canopy spaces,
- Ventilation and skylight spaces of the building,
- Balconies (open or closed),
- Elevator shafts and below the prominent building sections preventing waste gas release,
- Clearances providing fresh air to other units,
- Courts in between the buildings,
- Locations which may be directly exposed to wind resistance.
- The distance to the flue from the top of prominent roof or wooden coating should be at least 1.5 m. (Figure 4a)
- At locations where impact on flue outlet is possible, the flue outlet should be protected by stainless or galvanic steel wire-mesh cages. This should be considered at locations where there is vehicle traffic. (Figure 4b)
- At locations from where the people pass, for instance at sidewalks, the height of flue outlet should be at least 2m. (Figure 4c) For semi basement building facing sidewalks, this height may be at least 1 m. provided that the required safety measures are taken.
- It should be height of at least 0.3 m. at locations where there is no human and vehicle traffic. (Figure 4d)
- Regarding the conditions of applying the flue outlets of hermetic devices –of the flats at the top floors of the buildings- to skylight of the building, elevation at vertical direction should be made with the original parts of the producer company, and it should be reached to the ending point of the skylight. (In here, total flue length should be within the allowed limits.) Moreover, the distance in between the point of exit and roof ridge, number of flats benefiting from the skylight and the condition of windows should be assessed.

Min distanceto the roof

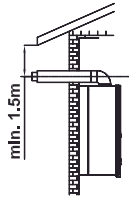

Human area

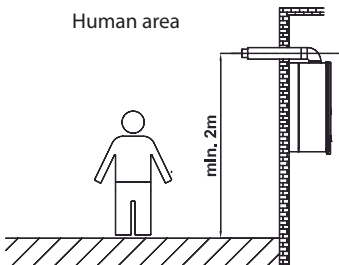

Vehicle area

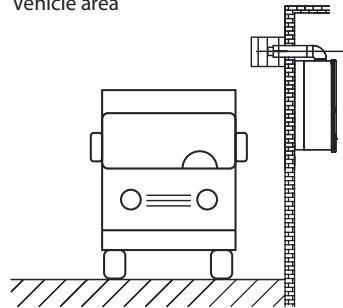
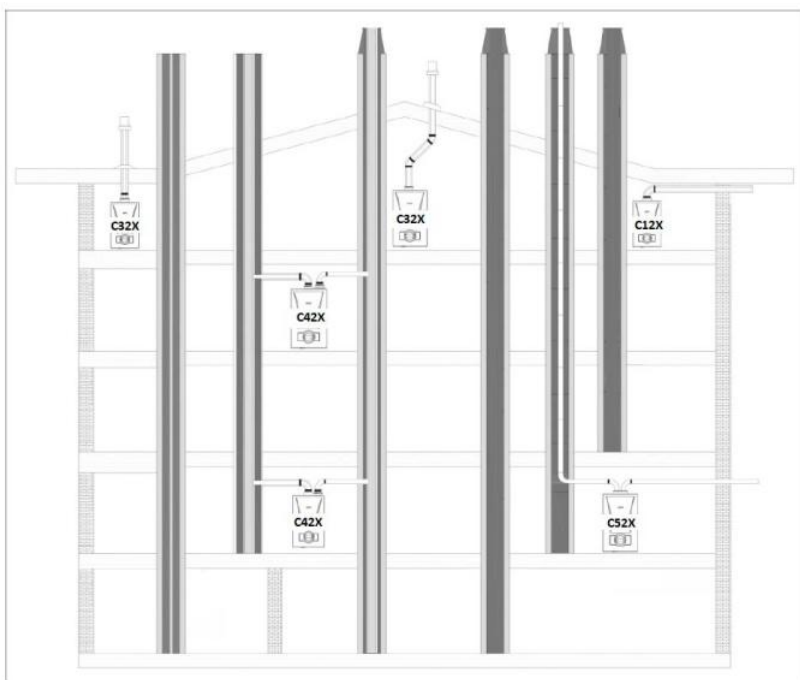
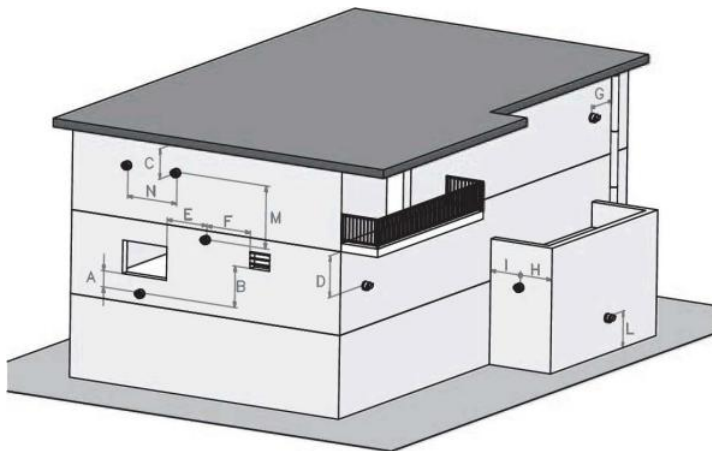

Figure 4



**Figure 4a**



POSITION	DISTANCE (cm)	POSITION	DISTANCE (cm)
A-Below a windows	60	G- Next to vertical or horizontal pipe	60
B- Below an air vent	60	H- Below the distance grille from the outside of the building	30
C- Below rain channel	30	I- Distance from the inner corner of the building	100
D- Under the balcony	30	L- From the ground or from the floor	180
E- Next to a window	40	M- Vertical distance of two fume outlets	250
F- Next to an air grill	60	N- Horizontal distance of two fume outlets	100

**Figure 4b**

- In C type devices, the horizontal outlets should be assembled by a 1-2% downward inclination at the outside for rain water etc. not to enter inside the device (Figure 5a).
- The distance of waste gas outlet with the opposite building should be at least 3 m. in the direction of discharge of waste gas (Figure 5b).
- There should be at least 2.5 m. upwards distance in between the flue outlets of C type devices. Moreover, the waste gas outlets of these devices should be 30 cm. below the bottom edge of the window (Figure 5c).
- "C" type devices below the ground level (at basements) can only be installed if the combustion air and was gas pipe lines of each device are opening to their own channels. The cross-section areas of the channels should be at least  $0.75 \text{ m}^2$  and the small edge size of the channel should be at least 0.5 m. There shouldn't be vents or windows opening to these channels.
- In C type devices, combustion air and waste gas pipe outlets should be at least at 5 m. horizontal distance from the fuel pumps and fuel tanks.

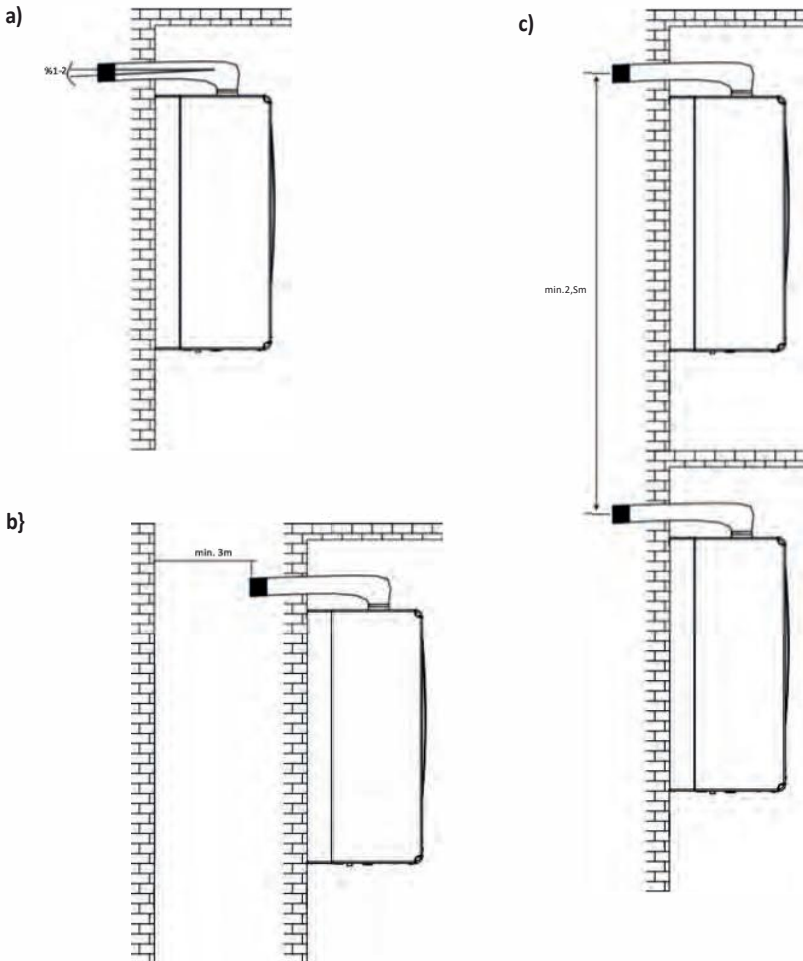

Figure 5

In case of assembly of the device at attics or at rooms under the roof/terrace,

- The flue outlet should be at least 40 cm higher than the roof (Figure 5d and 5e).
- The ceiling should be resistant to high temperature. “Hermetic flue group”, enabling the fresh combustion air supply and waste gas exit of the device, should be isolated with material resistant to high temperature at the roof space.
- If the ceiling is not of a material resistant to high temperature, the “hermetic funnel group” should be isolated with incombustible material as from the ceiling passage, or should be taken within a separate protection pipe.
- In respect of preventing condensation in the pipes, the part of hermetic flue group remaining at the roof space should be isolated.

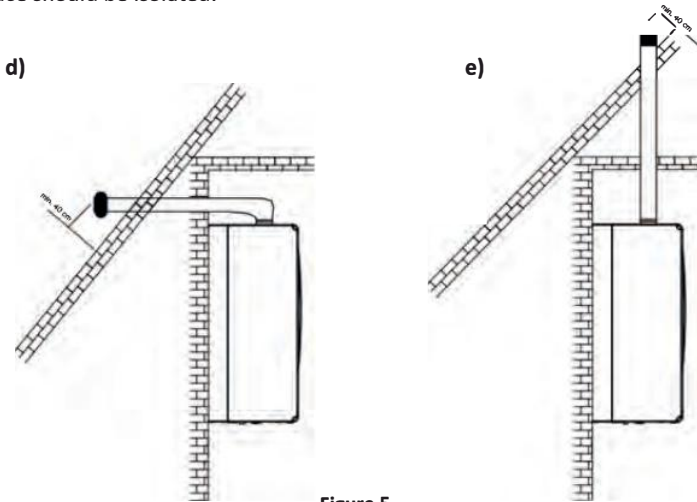

Figure 5

### Issues to be Considered in Flue Connections

After determining the location where the combi boiler will be assembled,

- The locations of lock screws of wall hanger bracket and assembly bracket are marked by using the assembly template on the last page of the usage and assembly guide of the device.
- After drilling the marked locations, the wall hanger bracket and assembly bracket are fixed to the wall by using the dowel and lock screws provided in the packaging of the device.
- After hoisting the combi boiler, the hanger bracket behind the combi boiler is placed on the hooks on the wall hanger bracket, and the combi boiler is hung on the wall.

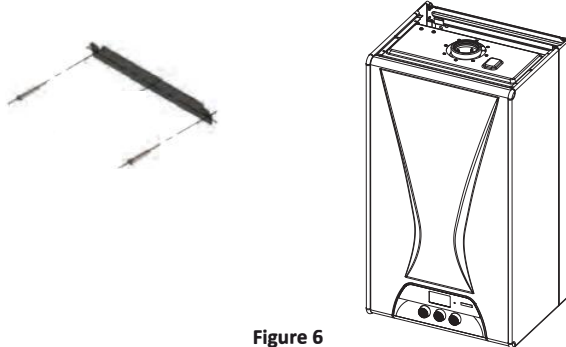

Figure 6

**Hermetic Type Flue Connections;**

Our combi boilers have the following hermetic flue connection options:

1. Horizontal flue connection (  $\varnothing$  60 /100 mm ) up to max. 4 meters
2. Vertical flue connection (  $\varnothing$  60 /100 mm ) up to max. 5 meters
3. Twin flue connection (  $\varnothing$  80/80 mm ) up to max. 8 meters

**for 28 kW**

1. 5 meters
2. 6 meters
3. 12 meters

In case of use of bend in flue connections, the lengths decrease by 1 m in the use of each 90° bend or in the use of two bends of 45°. At most three bend of 90° can be used (Figure 7).

a) Sample flue installation with one bend of 90°

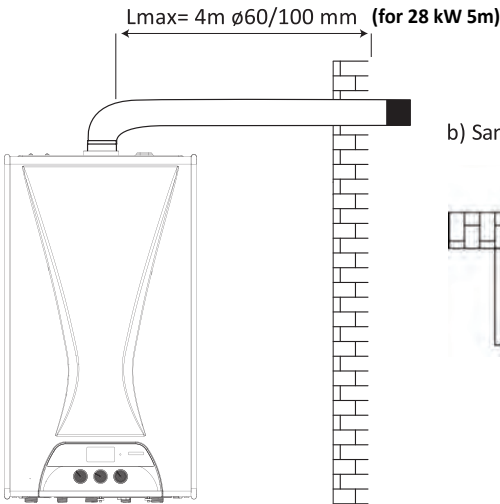

b) Sample flue installation with two bend of 90°

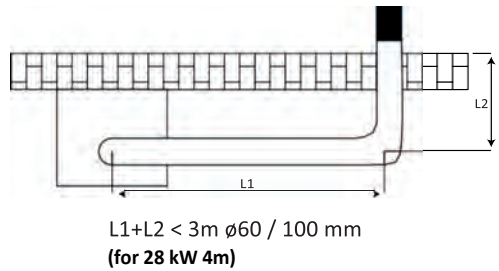

c) Sample flue installation with one bend of 90° and 45°

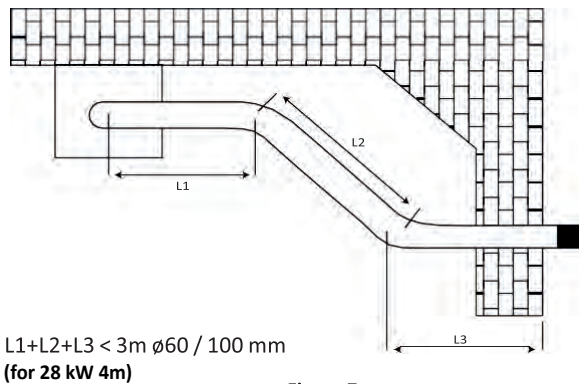

Figure 7

## Connection of Horizontal (Ø60/100mm) Hermetic Flue Set to the Combi Boiler

As your combi boiler is hermetic model, it takes the air used from the external environment, and discharges the waste gases arising as the result of combustion from the same flue group. The use and assembly of flue is very important for the extremely harmful waste gases not to be spread in the environment, thus the warnings should be considered while making the flue connections.

### Information

Horizontal outlets should be assembled with 1-2% downwards inclination for rain water etc. not to enter the device. (Figure Sa)

### Horizontal (Ø60/100 mm ) Hermetic Flue Set Consists of the Following Parts;

- 1 Flange gasket
- 2 Flue connection flange
- 3 Flange screws
- 4 Sealing gasket
- 5 90° bend
- 6 Clamp
- 7 Clamp screws
- 8 EPDM connection gasket
- 9 Flue outlet terminal
- 10 Interior wall connection flange
- 11 Exterior wall connection flange(EPDM)

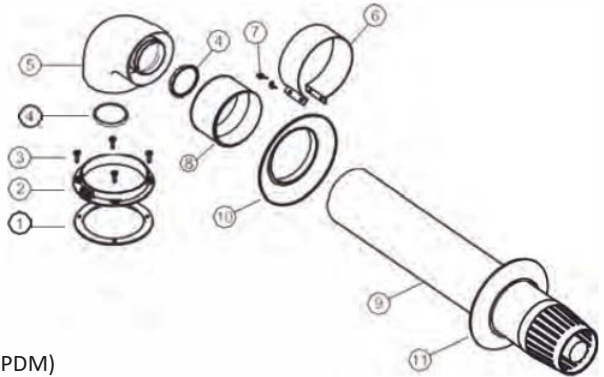

Figure 8

- Make the required flue selection for the flue connection to be made to outer environment from the location where your combi boiler is assembled. If the standard flue set is insufficient, select the most suitable accessories from our connection accessories list considering the warnings referred in our guide.
- Fix the flue connection flange through screwing to the holes on the combi boiler by using the flange gasket. (Figure 9a-9b)
- Place the 2 sealing gaskets -provided by the hermetic flue set- to interior pipe slots on both ends of the bend of 90°.
- Apply the EPDM connection gasket to the bend of 90° as to contact the limiting set inside the gasket.
- In order to group the flue outlet terminal, apply the exterior wall (EPDM) gasket to flue terminal as seen in Figure 9c. After passing the flue outlet terminal through the exterior side of the wall and from the previously opened hole, connect the interior wall connection gasket to flue terminal. Apply the other end of the EPDM connection gasket of your combi boiler -which is applied to flue bend of 90°- to the flue outlet terminal, and apply the clamp on the EPDM connection gasket and loosely tighten it with screw (Figure 9d). And then place the bend of 90° on the flue connection flange, and fix with tightening screws (Figure 9e). Finally, after tightening the screws which are placed on EPDM gasket and which are left loose, enable the flue and wall tightness by pushing the interior wall connection gasket as to touch the wall.

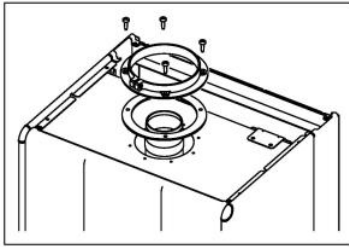

Figure 9a

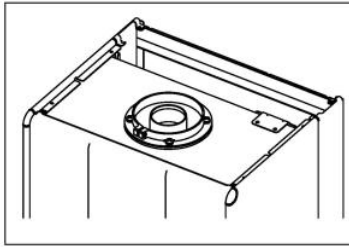

Figure 9b

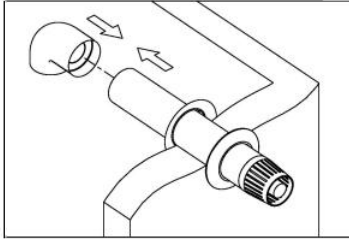

Figure 9c

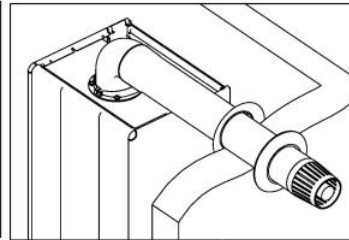

Figure 9d

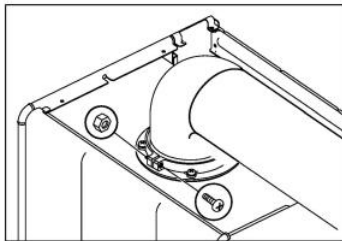

Figure 9e

### ■ Issues to be Considered in Flue Connection Extensions

In case the hermetic flue set -provided by the packaging of the product- is of insufficient length, additional hermetic flue accessories should be ordered from an authorized E.C.A. vendor as per requirement, and other hermetic flue accessories should not be used.

- (Ø60/100mm) Hermetic Flue Set Accessories (Figure-10)

- a) Extension pipe (500 mm), EPDM gasket, clamp and clamp screws
- Extension pipe (1000 mm), EPDM gasket, clamp and clamp screws (Figure - 10a)
- b) Bend of 90°, EPDM gasket, clamp and clamp screws (Figure-10b)

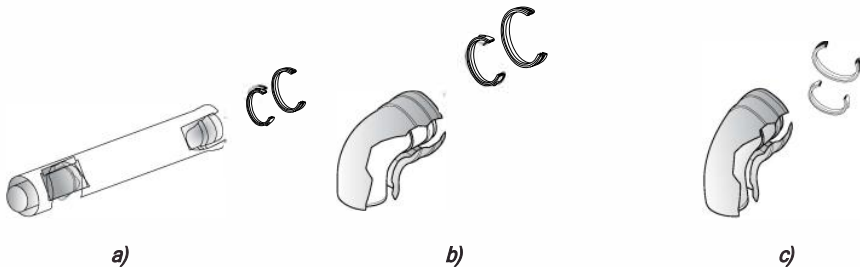

Figure 10



## →Assembly of restriction washer

In order to have an efficient combustion and proper waste gas values due to that, a restriction washer should be assembled at the outlet of fan as per the length of waste gas / fresh air terminal.

### Horizontal (Ø60/100mm) Hermetic Flue Lengths and Restriction Washers

Product Notation	Bend	L (m)	Lmax (m)	Restriction Washer (mm)
GELIOS PLUS 24 , 20 kW	1x90°	≤ 1	4	Ø 43
	1x90°	1 < ≤ 2		Restriction washer will not be used
	1x90°	2 < ≤ 3		Restriction washer will not be used
	1x90°	3 < ≤ 4		Restriction washer will not be used
	2x90°	≤ 1	3	Restriction washer will not be used
	2x90°	1 < ≤ 2		Restriction washer will not be used
	2x90°	2 < ≤ 3		Restriction washer will not be used

Product Notation	Bend	L (m)	Lmax (m)	Restriction Washer (mm)
GELIOS PLUS 16 , 13 , 11 kW	1x90°	≤ 1	4	Ø 39
	1x90°	1 < ≤ 2		Restriction washer will not be used
	1x90°	2 < ≤ 3		Restriction washer will not be used
	1x90°	3 < ≤ 4		Restriction washer will not be used
	2x90°	≤ 1	3	Restriction washer will not be used
	2x90°	1 < ≤ 2		Restriction washer will not be used
	2x90°	2 < ≤ 3		Restriction washer will not be used

Product Notation	Bend	L (m)	Lmax (m)	Restriction Washer (mm)
GELIOS PLUS 28 kW	1x90°	≤ 1	5	Ø 43
	1x90°	1 < ≤ 2		Ø 47
	1x90°	2 < ≤ 3		Ø 47
	1x90°	3 < ≤ 4		Restriction washer will not be used
	1x90°	4 < ≤ 5	Restriction washer will not be used	
	2x90°	≤ 1	4	Ø 47
	2x90°	1 < ≤ 2		Ø 47
	2x90°	2 < ≤ 3		Restriction washer will not be used
	2x90°	3 < ≤ 4		Restriction washer will not be used
2x90°	3 < ≤ 4	Restriction washer will not be used		

Table 3

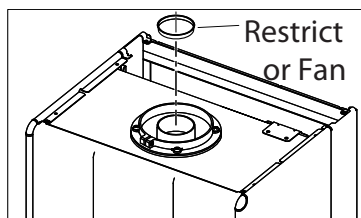

Figure

## ■ Connection of Vertical Hermetic Flue Set to the Combi Boiler

➔Your combi boiler has the ability to be vertically connected to flat and aslope roofs through the connection accessories as per the status of the environment where it will be assembled. In connections made as straight, it is being reached to an height of 4 meters with (Ø60/100mm) vertical flue set. The lengths in case of use of bend have been shown in Table 5.

Connection elements for vertical flue connection,

1. Vertical flue kit (Ø60/100mm)
2. Vertical flue adaptor (Ø60/100mm) - (with drainage)
3. Extension 500mm / 1000mm (Ø60/100mm)
4. Bend of 45° (Ø60/100mm)
5. Bend of 90° (Ø60/100mm)
6. Inclined roof adaptor (Ø60/100mm)

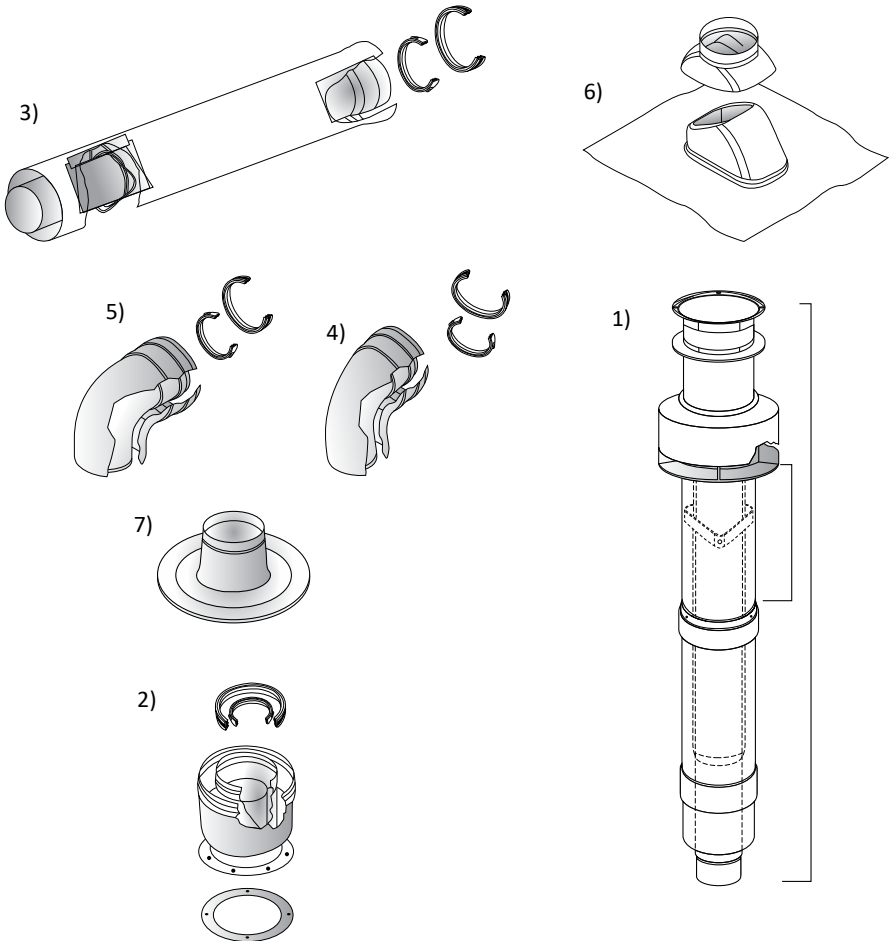

Figure 14

**Diameters of  $\phi 60/100$ mm Vertical Hermetic Flue Restriction Washer**

Product	Bend	L (m)	Lmax (m)	Restriction Washer (mm)
GELIOS PLUS 24 , 20 kW	-	$\leq 1$	5	$\phi 43$
	-	$1 < \leq 2$		Restriction washer will not be used
	-	$2 < \leq 3$		Restriction washer will not be used
	-	$3 < \leq 4$		Restriction washer will not be used
	-	$4 < \leq 5$		Restriction washer will not be used
	1x90°	$\leq 1$	4	Restriction washer will not be used
	1x90°	$1 < \leq 2$		Restriction washer will not be used
	1x90°	$2 < \leq 3$		Restriction washer will not be used
	1x90°	$3 < \leq 4$		Restriction washer will not be used
	2x90°	$\leq 1$	3	Restriction washer will not be used
	2x90°	$1 < \leq 2$		Restriction washer will not be used
	2x90°	$2 < \leq 3$		Restriction washer will not be used
	Product	Bend	L (m)	Lmax (m)
GELIOS PLUS 16, 13, 11 kW	-	$\leq 1$	5	$\phi 39$
	-	$1 < \leq 2$		Restriction washer will not be used
	-	$2 < \leq 3$		Restriction washer will not be used
	-	$3 < \leq 4$		Restriction washer will not be used
	-	$4 < \leq 5$		Restriction washer will not be used
	1x90°	$\leq 1$	4	Restriction washer will not be used
	1x90°	$1 < \leq 2$		Restriction washer will not be used
	1x90°	$2 < \leq 3$		Restriction washer will not be used
	1x90°	$3 < \leq 4$		Restriction washer will not be used
	2x90°	$\leq 1$	3	Restriction washer will not be used
	2x90°	$1 < \leq 2$		Restriction washer will not be used
	2x90°	$2 < \leq 3$		Restriction washer will not be used

Product	Bend	L (m)	Lmax (m)	Restriction Washer (mm)
GELIOS PLUS 28 kW	-	$\leq 1$	6	$\varnothing 43$
	-	$1 < \leq 2$		$\varnothing 47$
	-	$2 < \leq 3$		$\varnothing 47$
	-	$3 < \leq 4$		Restriction washer will not be used
	-	$4 < \leq 5$		Restriction washer will not be used
	-	$5 < \leq 6$		Restriction washer will not be used
	1x90°	$\leq 1$	5	$\varnothing 47$
	1x90°	$1 < \leq 2$		$\varnothing 47$
	1x90°	$2 < \leq 3$		Restriction washer will not be used
	1x90°	$3 < \leq 4$		Restriction washer will not be used
	1x90°	$4 < \leq 5$		Restriction washer will not be used
	2x90°	$\leq 1$	4	$\varnothing 47$
	2x90°	$1 < \leq 2$		Restriction washer will not be used
	2x90°	$2 < \leq 3$		Restriction washer will not be used
2x90°	$3 < \leq 4$	Restriction washer will not be used		

Table 5

## Vertical Flue Connections

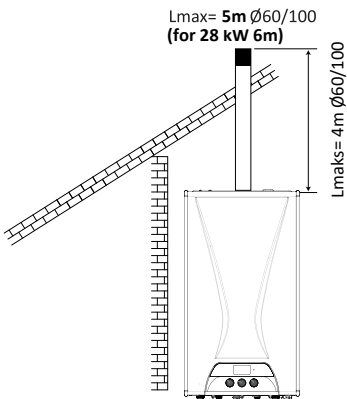

Figure 15a

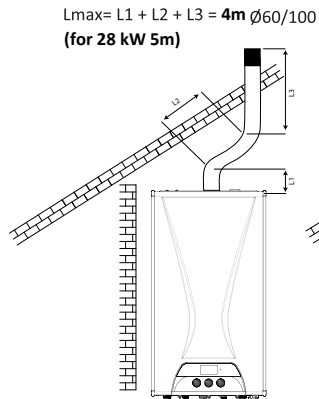

Figure 15b

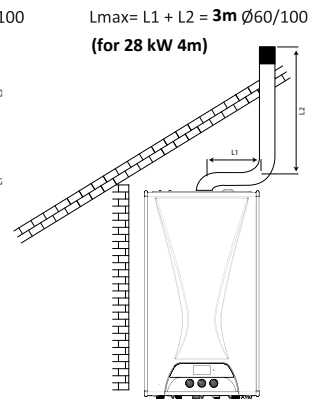

Figure 15c

## Connection of Twin Hermetic Flue Set to the Combi Boiler

Twin flue connection is made as per the status of the environment where your combi boiler will be assembled, and it takes the air used from the external environment through the first pipe, and discharges the waste gases arising as the result of combustion to the external environment through the second pipe. The lengths of waste gas and fresh air connection pipes, and numbers of bends to be used have been provided in Table 6. (Figure 17)

Connection elements for twin flue connection (Figure 16)

1. Twin hermetic flue set  $\varnothing$  80x80 mm (Figure 16a)
2. Extension 500 mm / 1000 mm  $\varnothing$  80x80 mm (Figure 16b)
3. Bend of  $90^\circ$   $\varnothing$  80x80 mm (Figure 16c)
4. Bend of  $45^\circ$   $\varnothing$  80x80 mm (Figure 16d)

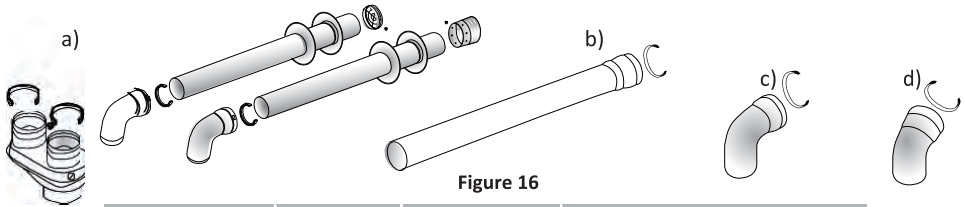
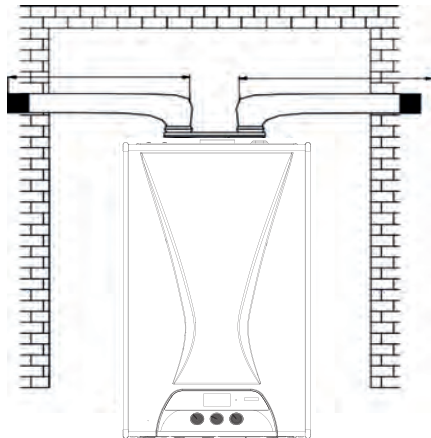

Figure 16

Product	Bend	Lmax (m) (a+b)	Restriction Washer (mm)
GELIOS PLUS 28 kW	2x90°	12	$\varnothing$ 43
GELIOS PLUS 24 kW	2x90°	8	$\varnothing$ 43
GELIOS PLUS 20 kW	2x90°	8	$\varnothing$ 43
GELIOS PLUS 16 kW	2x90°	8	$\varnothing$ 39
GELIOS PLUS 13 kW	2x90°	8	$\varnothing$ 39
GELIOS PLUS 11 kW	2x90°	8	$\varnothing$ 39

Table 6



## ■ Connections of Gas and Water Pipe



### Information

Assembly bracket group is optional. You can procure from E.C.A. vendors in case of requirement.

- The water and gas connections in between the assembly bracket fixed on the wall and the combi boiler are made by the pipe group and nipples as seen in the figure (Figure 18).

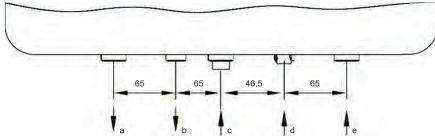

Figure 18a Option 1

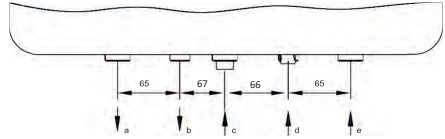

Figure 18b Option 2

- a) Central heating pipe 3/4" outlet line (hot)
- b) Domestic hot water pipe 1/2" outlet line (hot)
- c) Gas inlet pipe line 3/4"
- d) Domestic hot water pipe 1/2" inlet line (cold)
- e) Central heating pipe 3/4" return line (cold)

- Valves conforming the diameters of water and gas pipe lines should be placed on such pipe lines. Moreover, strainer should be placed on running water pipe (1/2") inlet and central heating pipe (3/4") return lines.
- The hose coming out of the 3 bar safety cock should be connected to waste water outlet line.
- The connection in between the device and the gas line inside the building should be made by a flexible connector (flexible pipe).

## ■ Electrical Connection



**DANGER:** While making the electrical connection of the device, it should be cared not to have voltage on the electric line.

Connect your device to 230V AC, 50 Hz grounding plug line. If the supply cable is damaged, it should be replaced by E.C.A. authorized services.

The electrical connection cable of the device should be supplied from a grounding plug line that will be able to provide sufficient voltage (230 VAC, 50 Hz). Card malfunctions and damages of device due to voltage fluctuations and lack of grounding are out of the scope of warranty.

## ■ Room Thermostat (Optional)

In order to enable the heating control of the system, one of the optional room thermostats compatible with your device may be used.



E.C.A. On/Off Room Thermostat  
T6360  
7006901312

**Figure 19a**



E.C.A. Smart Combi  
Boiler Kit  
7006907531

**Figure 19b**



E.C.A. Digital Room Thermostat  
Cordless Programmable CM727  
7006902046

**Figure 19c**



E.C.A. D Digital Room Thermostat  
7006902502

**Figure 19d**



E.C.A. On/Off Cordless Room  
Thermostat 7006907522

E.C.A. On/Off Cable Room Thermostat  
7006907519

**Figure 19e**



E.C.A. Programmable Digital  
Room Thermostat - CM707  
7006901313

Cordless 7006901501

**Figure 19f**

## Information

- Responsibility will not be accepted due to inconveniences to arise from the use of different brands of thermostat.
- Room thermostat connection is being seen on the electric circuit scheme. (Page 5, Figure 1)

### Information Required for Secure and Economic Use of Your Combi Boiler

- The isolation of your building is extremely important. As heat loss is minimized at houses whose walls are isolated, on which jacketing is made and with double glazing, significant energy saving is ensured.
- The use of thermostatic valves on your radiators enables the room temperatures to remain constant and fuel saving.
- Cutting down the radiator valves at rooms which will not be used for a long period and keeping their doors closed decreases fuel consumption.
- If you use your combi boiler with room thermostat, less fuel consumption is achieved by keeping the temperature of space at the set level.
- As closing the tops and fronts of radiators with furniture etc. negatively affects hot air circulation, it prevents heating up of the environment and causes the increase of fuel consumption.
- If you will leave your device in operating state at late hours, keeping the water temperature of central heating circuit low will enable saving.
- Of you feel that the room temperature is high, the radiator valves should be cut down instead of opening the windows.

### START-UP AND USAGE

#### Final Controls and Operations Required to be Performed Before Start-Up

- As the result of determining the location of assembly of the combi boiler in accordance with the standards of TSE and authorized gas company and hanging of it, and as the result of completion of assembly by completing the funnel, electric, water and gas connections, the following controls and operations should be performed by authorized installer vendor

## Information

#### 1) Filling water to the combi boiler and central heating system

- First the electric connection of the combi boiler is made. All the radiator valves are opened.
- The valves of central heating outlet - return lines of the combi boiler should be open. Check it.  
After this operation, start the filling operation by slowly opening the filling valve.

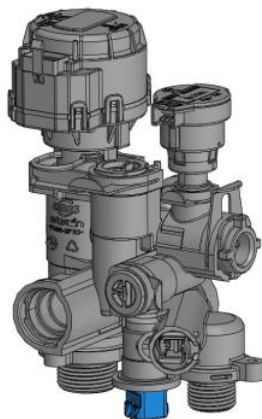



- During the performance of water filling operation, the system's water pressure value is followed-up from the pressure indicator on the LCD display of your device. The pressure value on LCD display should be in between 1-1.5 bar. When it is reached to this value, close the filling valve.



**CAUTION:** Close the water filling valve, the water of the system may damage the environment by leaking.

- Whether there is air in the central heating circuit is controlled from the air relief cocks on the radiator. For a full efficient heating, all the air should be discharged from the system. Moreover, in case of being required, the air may be discharged by the air relief cock on the expansion tank.
- After air discharge, check the water pressure on LCD display again, and repeat the filling of water in case of its decrease.
- Finally, check whether there exists leakage in radiators, system's pipes and connections.



**CAUTION:** It is recommended for you to not to use well water, natural spring water etc. except the mains water in order to prevent the calcification of the exchanger.

**2) Check the running water installation by opening the hot water tap. Look for any leakage on the pipes of the system.**

**3) The waste gas flue group should have been installed by original parts in accordance with the instructions.**

#### **IMPORTANT,**

**The electrical connection of the device should have been connected to a grounding plug line that will be able to provide sufficient voltage (230 V AC, 50 Hz).**

The gas line should have been controlled by the authorized gas company and should be open.

After completion of all these operations, the authorized service should be called for the commissioning of the device.



**In case of gas leakage at your house, immediately close the gas valve or hood of gas tube. Ventilate the environment. Call the gas company or authorized service.**



***The start-up of the device should be performed by the authorized service.***



By the end of start-up following the installation of the device, request information from the authorized service regarding the operation and security mechanisms of the device.



Figure 20

### 1) Position Selection Button

It enables opening/closing of your device, selection of summer/winter position, and resetting of the device.

❄️ **Winter Position:** Turn the position selection button to the left, to the “❄️” symbol. In this position, you can enable the heating up of central system and also heating up of the running water.

☀️ **Summer Position:** Turn the position selection button to the right, to the “☀️” symbol. In this position, you can enable the heating up of only the running water.

• **Closure Position:** Take the position selection button to “• - OFF” position. In this position, the operation of your device will end.

**RESET Reset Position:** When your device breaks down, the malfunction warning LED will start to blink, and reset phrase will appear on the left hand side of the LCD display along with the “RESET” symbol. In this case, take the position selection button to “OFF - Reset” position, and turn to summer or winter position after waiting for 5 seconds. If the malfunction is continuing, repeat this operation for a few times. If the malfunction is still continuing despite resetting, consult to the closest E.C.A. service.

**Bar Position** Turn the position selection button to the right, to the bar symbol. In this position water pressure will be shown on screen.



**If the button is left at bar position, boiler will run in summer mode so, central heating system will not get hot water.**

### 2) Central Heating Water Temperature Adjusting Button

While the position selection button is in winter “❄️” position, you can select a comfort temperature as you like in between 30°C - 80°C by turning the central heating water temperature adjusting button in between min. and max.

### 3) Domestic Hot Water Temperature Adjusting Button

While the position selection button is in summer “☀️” or winter “❄️” position, you can select a running water temperature in between 35°C - 64°C by turning the domestic hot water temperature adjusting button in between min. and max.

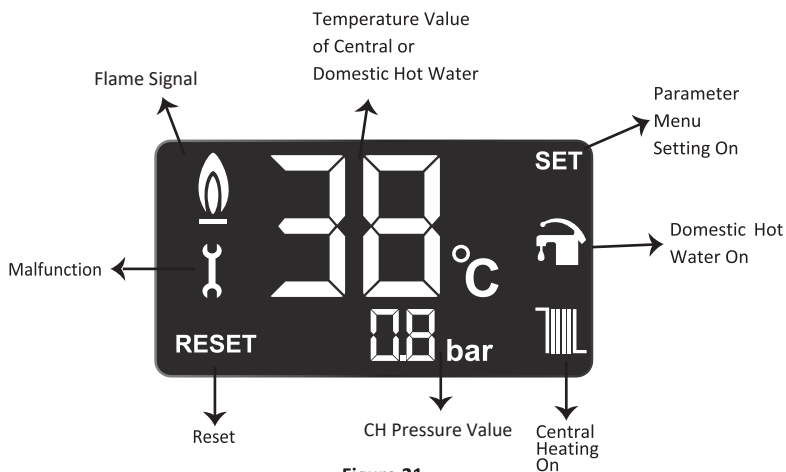

Figure 21

#### 4) LCD Display

You can see all the operation functions over the LCD display on the control panel of the device. While the device is in closed position, there will not be any view on the LCD display.

While your combi boiler is operating in central heating position, “|||||” symbol will appear on the right bottom corner of the LCD display, and the temperature of water in the central system will be seen numerically on the display.

### OPERATION OF DEVICE

**WINTER POSITION:** Take the position selection button to winter position. (Figure 22) In this position, you can meet both your central heating and domestic hot water requirements. You can set the central system’s heating temperature in between 30°C - 80°C by the central system temperature adjusting button, and the domestic hot water’s temperature in between 35°C - 64°C by the domestic hot water temperature adjusting button.

LCD display lightens by the operation of the device, and the device completes the pre-controls and enables the combustion of boiler by making the ignition. Thus the device steps in, and operates in order to provide both central heating and domestic hot water. During opening of any tap in the hot water usage circuit, the device stops central heating and gives the priority to hot water use, and when the tap is closed, central heating continues automatically.

While your combi boiler is in winter position, if there is no central heating circuit and domestic hot water usage requirement, the “☕” and “|||||” symbols light as constant on the display. After temperature setting to be made with hot water usage button or central heating circuit button, the temperature set appears on the display for 5 seconds.

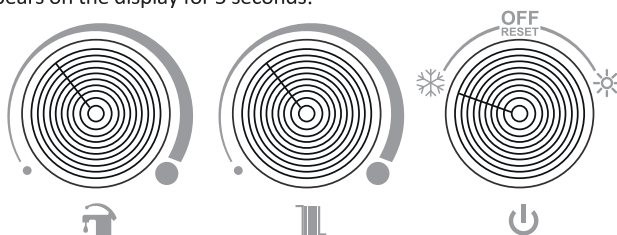

Figure 22

After the boiler performs ignition, “🔥” symbol appears on the display. If there is heat requirement in the central heating circuit, “🏠” symbol blinks, and “🌡️” symbol lights constantly. If there is domestic hot water requirement, “🚿” symbol lights constantly, and “🏠” symbol blinks. In order to turn off the device, take the position selection button to “OFF” position, and the light on the LCD display on control panel will fade away.

**SUMMER POSITION:** Take the position selection button to summer position. In this position, you can only meet your domestic hot water requirement. By the domestic hot water temperature adjusting button, you can select the temperature of domestic hot water in between 35°C- 64°C. When you take the position selection button to summer position, the device waits as being ready to step in, and during opening of any tap on the hot water usage circuit, the device operates and provides hot water, and the device stops its operation automatically when the tap is closed.

When your combi boiler is in summer position, only the “🏠” symbol appears on the display, and the “🌡️” symbol doesn’t appear. If there is no domestic hot water request in summer position, only the “🏠” symbol lights constantly on the display. When domestic hot water request arises, the “🏠” symbol on the display will start to blink. In order to turn off the device, take the position selection button to “OFF” position, and the light on the LCD display on control panel will fade away.

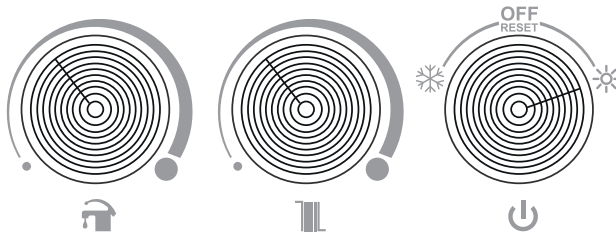

Figure 23

**Freeze Protection**

Along the winter season, when the outlet temperature of system’s water decreases below 6°C, freeze protection function steps in, and your device continues to operate until the outlet temperature of system’s water reaches 15°C. For the freeze protection function to operate, the following conditions should be controlled and enabled by the customer.

1. Electric supply of the device should be open.
2. Gas valve and radiator valves should be open.
3. Water pressure of the system should be suitable.

Important Note: Free protection function only protects your device, it doesn’t protect your system.

**Pump & 3 Way Valve Blockage Protection Function**

Blockage protection protects the pump against blockage in cases when the pump doesn’t operate for a long period, this function protects the pump against blockage by operating the pump for 5 seconds once in 24 hours as long as the device is connected to electric circuit. The same feature is also valid for 3 way valve, the 3 way valve protection protects the valve against blockage by enabling the deflexion of 3 way valve -if it has not changed direction in the recent 24 hours- as long as the device is connected to electric circuit.

## INFORMATION FOR AUTHORIZED SERVICE

### Gas Pressure Setting

As the heating capacity of the device is directly dependent on gas pressure, the device's (mechanically) minimum and maximum heating capacity becomes adjusted by the determination of operation pressure range.

		24HM	28HM
Natural gas	max. gas pressure (mbar)	12,3	11,9
	min. gas pressure (mbar)	1,4	1,25

Table 7

- In order to make the min. gas setting of the device, it is required to operate at min. capacity, and in order to make the max. gas setting of it, it is required to operate at max. capacity.
- The front panel is removed.
- By removing the screw connecting the top edge of the control panel, the control panel is tilted forward, and it is reached to gas valve for setting.

#### →Setting the maximum outlet pressure;

- The device is taken to maximum operation position.
- Gas outlet pressure measurement port's screw is loosened.
- U manometer is connected to gas outlet pressure ( $\varnothing 9$  mm) measurement port (Figure 24).
- After removing the protection cap of maximum pressure regulator's adjustment screw –shown by no 2 in Figure 24-, the gas flow towards the burner increases by slowly turning it clockwise, and otherwise it decreases.
- By monitoring the pressure values from U manometer, the required pressure value is obtained. Setting of maximum outlet pressure is made only for natural gas, the adjustment screw of maximum pressure regulator is completely tightened.

#### →Setting the minimum outlet pressure;

- The device is taken to minimum operation position.
- U manometer is connected to gas outlet pressure ( $\varnothing 9$  mm) measurement port (Figure 24).
- Gas flow decreases by turning the minimum pressure regulator's adjustment screw –shown by no 1 in Figure 24- clockwise, and otherwise it increases.

- The required pressure value is obtained by monitoring the pressure values from U manometer.
- After making the settings, the screw removed from the outlet pressure measurement port is fastened again and tightened for the measurement of gas valve's outlet pressure.
- The removed front panel and control panel are fastened again.

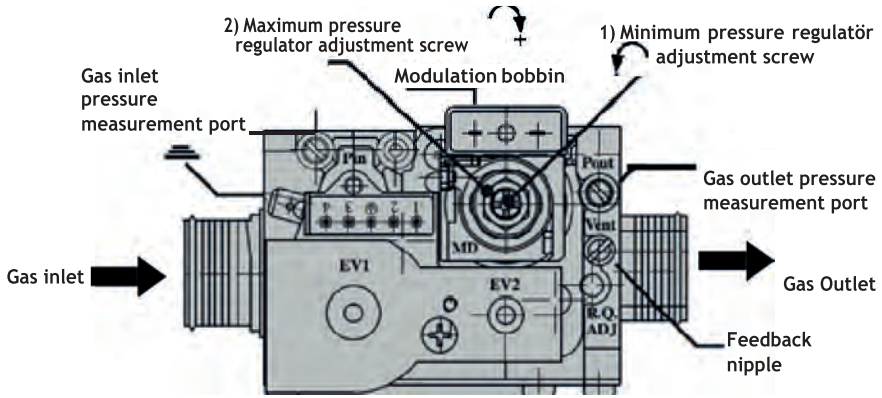

Figure 24

### Amendment of Injector Nozzles



**DANGER:** During the amendment of injector nozzles, gas line valve and electric circuit should be shut off.

- The device is taken to OFF position, and gas valve is shut off.
- The front panel is removed, and the control panel is tilted forward.
- The cover of combustion body is removed.
- Burner is removed, and it is reached to the burner manifold.
- Injector suitable to fuel type should be fastened (Table 8). There are 11 injectors on the boiler.  
(For 28 kW, there are 13 injectors on the boiler.)

	Diameter of Injector (Polidoro Burner)
Natural gas	ø 1,32 mm

Table 8

## ➔GAS LEAKAGE TEST

- Apply the foam obtained by soapy water to all gas pipe connections. The formation of bubble indicates gas leakage on the connection.
- If gas leakage is determined, tighten that connection very well.
- Control leakage again by applying foam on connection points.
- If gas leakage is continuing, change the seal (gasket) and/or the connecting pieces.



**CAUTION:** During gas leakage test, soapy water and foam should be kept far from the electrical connections.

## DETERMINATION OF ERROR / MALFUNCTION AND TROUBLESHOOTING

There are various controls for the safe operation of the device. During these controls, the differences in control values encountered by the system are displayed on the LCD display on the control panel, (Figure 25).

For detailed information on error and malfunction codes, you can look at the explanations in Tables 9



**Figure 25**

➔The safety of the device has been ensured in two ways. (For instance, F1 and F4 error codes)

a) In case of error, the device will pass to locking position. In this case, while the error code is appearing on the LCD display. In that case, take the position selection button to "RESET" from summer or winter position, and wait for 5 seconds. And then, if the malfunction is continuing when you take the button to summer or winter position again, repeat this operation for a few times. If the malfunction still continuing despite resetting, consult to the closest E.C.A. service.

b) And in case of malfunction, the device will pass to block position. In cases of blockage (F2, F3, F5, F6 and F7), the malfunction cannot be reset, and it is required to remove the problem causing malfunction.

<b>Error / Fault and Fault Code</b>	<b>Probable Cause</b>	<b>Solution</b>
<b>F1- Overtemperature locking</b>  The red warning LED blinks on the LCD screen along with the fault code F1 to indicate the fault.	<ul style="list-style-type: none"> <li>• If the temperature of the central heating circuit exceeds 105 °C, overtemperature locking will occur.</li> </ul>	<ul style="list-style-type: none"> <li>• Check the water circuits.</li> <li>• Check that the central heating circuit valves are open.</li> <li>• Turn ON / OFF switch to OFF / Reset position and wait for 5 seconds.</li> <li>• If the lock is still continuing (or repeats) after reset, notify your E.C.A. Authorized Service.</li> </ul>
<b>F2- Hot Domestic Water Sensor Fault</b>  The red warning LED blinks on the LCD screen along with the fault code F2 to indicate the fault.	<ul style="list-style-type: none"> <li>• If the Hot Domestic Water sensor goes out of its normal operating range and this condition lasts for more than 10 seconds, the system gets blocked.</li> <li>• The sensor connection cables may be snapped or dislocated.</li> <li>• The cables may have touched each other.</li> </ul>	<ul style="list-style-type: none"> <li>• The sensor remains in the fault position until it is operating. If the fault condition persists, consult the E.C.A. Authorized Service.</li> </ul>
<b>F3- Central Heating circuit supply sensor fault</b>  The red warning LED blinks on the LCD screen along with the fault code F3 to indicate the fault.	<ul style="list-style-type: none"> <li>• If the Hot Domestic Water sensor goes out of its normal operating range and this condition lasts for more than 10 seconds, the system gets blocked.</li> <li>• The sensor connection cables may be snapped or dislocated.</li> <li>• The cables may have touched each other.</li> </ul>	<ul style="list-style-type: none"> <li>• The sensor remains in the fault position until it is operating. If the fault condition persists, consult the E.C.A. Authorized Service.</li> </ul>
<b>F4- No flame signal fault</b>  When you bring the operating switch to the Summer or Winter position, the F4 fault code appears on the screen and the red warning LED starts flashing.	<ul style="list-style-type: none"> <li>• Electronic ignition has not occurred. It occurs because there was no flame in the burner after 3 attempts of ignition.</li> </ul>	<ul style="list-style-type: none"> <li>• Check that the gas inlet valves are open.</li> <li>• It is set to Off/Reset position and waited for 5 seconds and set to On position again.</li> <li>• If the fault condition persists, consult the E.C.A. Authorized Service.</li> </ul>
<b>F5- (APS) Air Pressure Sensor Fault</b>  The red warning LED blinks on the LCD screen along with the fault code F5 to indicate the fault.	<ul style="list-style-type: none"> <li>• There may be a problem with the flue suction.</li> <li>• The sensor connection cables may be snapped or dislocated.</li> <li>• The cables may have touched each other.</li> </ul>	<ul style="list-style-type: none"> <li>• The cables may have touched each other.</li> <li>• Turn ON / OFF switch to "Off/Reset" position and wait for 5 seconds.</li> <li>• If you haven't got any result from all trials, consult the ECA Authorized Service.</li> </ul>
<b>F6- Outside Air Sensor Fault</b>  It appears on the LCD screen with the F6 fault code.	<ul style="list-style-type: none"> <li>• Check the sensor connection cables, the cables may be dislocated or snapped.</li> <li>• The related cables may have touched each other.</li> </ul>	<ul style="list-style-type: none"> <li>• The appliance can be controlled with the central heating temperature-regulating switch on the control panel without the outside air sensor. However, consult the ECA authorized service for the solution.</li> </ul>
<b>F7- Low Water Pressure Warning</b>  The red warning LED blinks on the LCD screen along with the fault code F7 to indicate the fault.	<ul style="list-style-type: none"> <li>• If the installation water pressure falls below 0,8 bar, the appliance will not work.</li> </ul>	<ul style="list-style-type: none"> <li>• The appliance will continue to fail until the installation pressure reaches the minimum value of 0,8 bar.</li> <li>• Check that the connection valves are open.</li> <li>• Check the sealing of the installation connections.</li> </ul>
<b>F8- Low Voltage Warning</b>  The red warning LED blinks on the LCD screen along with the fault code F8 to indicate the fault.	<ul style="list-style-type: none"> <li>• If the mains voltage is below 165V, the appliance will not operate.</li> </ul>	<ul style="list-style-type: none"> <li>• Check the mains voltage.</li> <li>• If the mains voltage is 230 V and the error persists, contact the E.C.A. Authorized Service.</li> </ul>
<b>F9- Gas Valve Feedback Error</b>  The red warning LED blinks on the LCD screen along with the fault code F9 to indicate the fault.	<ul style="list-style-type: none"> <li>• If there is an error in the gas valve feedback control circuit, this error is displayed on the screen and the appliance is locked.</li> </ul>	<ul style="list-style-type: none"> <li>• Consult the E.C.A. Authorized Service.</li> </ul>
<b>F15- High Pressure Sensor Warning</b>  The red warning LED blinks on the LCD screen along with the fault code F15 to indicate the fault.	<ul style="list-style-type: none"> <li>• The installation water pressure has risen, and if the drain valve clogging is present, the error appears and the appliance does not operate.</li> </ul>	<ul style="list-style-type: none"> <li>• It remains in the fault position until the pressure drops. If the fault condition persists, consult the E.C.A. Authorized Service.</li> </ul>
<b>F16- Central Heating Circuit High Temperature Warning While the Domestic Water is Active</b>  The red warning LED blinks on the LCD screen along with the fault code F16 to indicate the fault.	<ul style="list-style-type: none"> <li>• The plate heat exchanger of the appliance may be contaminated.</li> </ul>	<ul style="list-style-type: none"> <li>• Consult the E.C.A. Authorized Service.</li> </ul>

**Table 9**

OC : Indicates that the exterior air sensor is active.

CC : Indicates that the exterior air sensor is not active. It is not an error /malfunction code, this information appears on the LCD display when the energy of combi boiler is cut and energy is given again.



950mm

740 mm

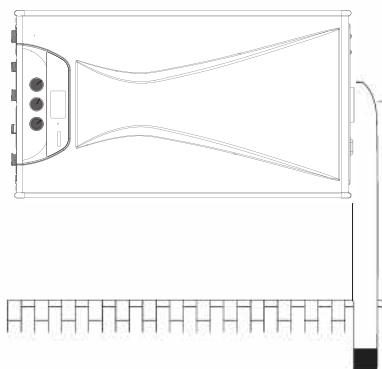
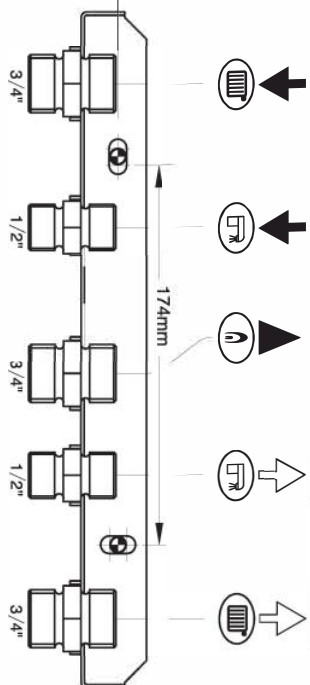

530 mm

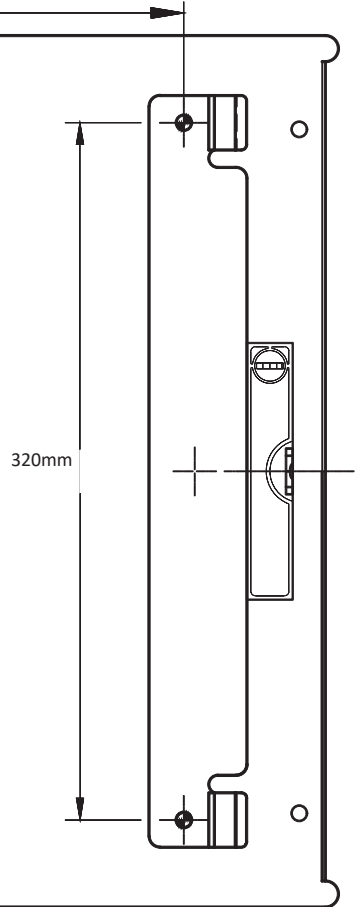
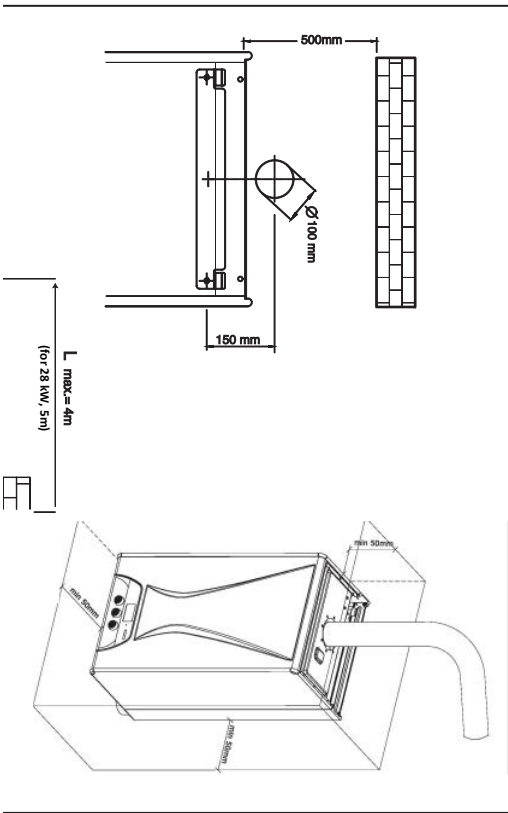

# ANNEXES

## 1) Characteristic curve of water pressure height of the pump (Pump head – flow rate)

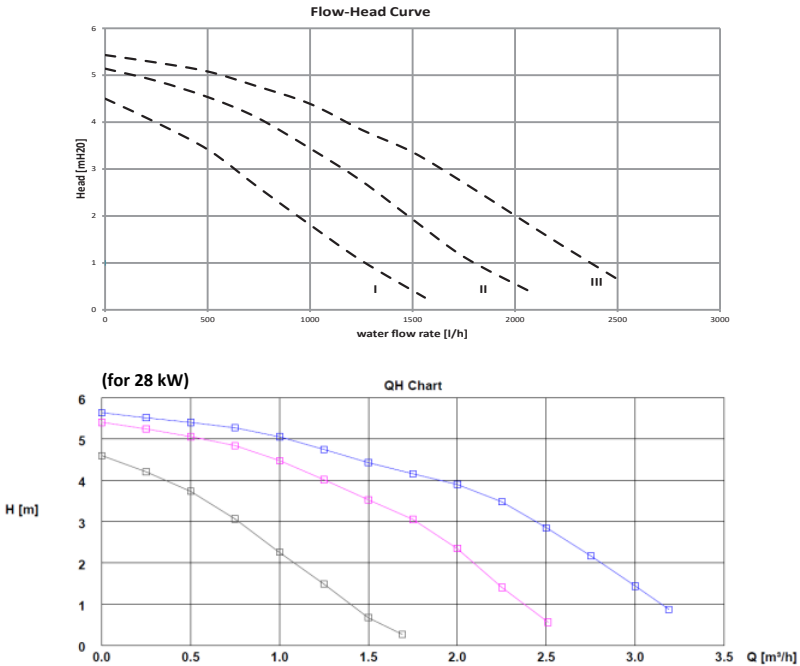

Figure 26

## 2) Injector gas pressure for natural gas (mbar) - capacity (kW) diagram

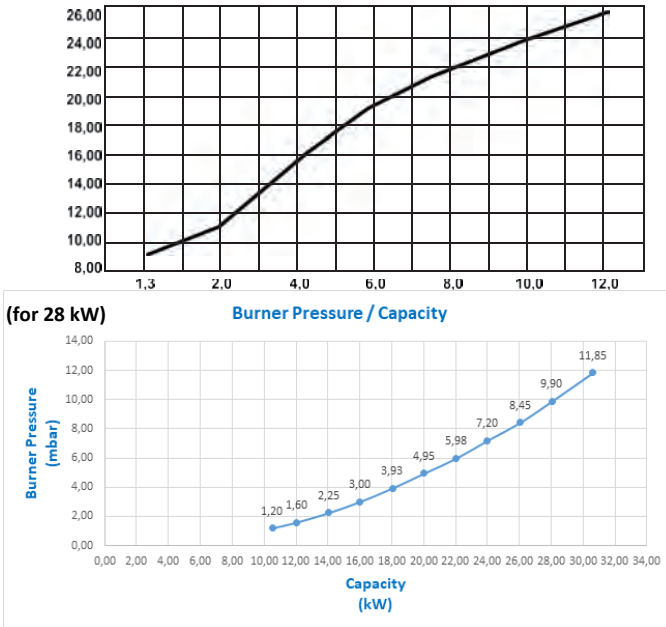

Figure 27



7006907068-1.0