



*proteus* PREMIX

## PROTEUS PREMIX CONDENSING BOILER

PROTEUS PREMIX PPR  
14-20-24-28-30-35-42-45 HM/HCH/HST

INSTALLATION AND USER'S  
OPERATING INSTRUCTIONS





# INTRODUCTION

1- INTRODUCTION .....	4
2-GUARANTEE AND SERVICE .....	4
3-DEFINITIONS OF SYMBOLS .....	4
4-SAFETY RULES AND WARNINGS .....	5
5-PRODUCT .....	6
5.1- General Specifications .....	6
5.2- Notations of Product .....	7
5.3- Detailed View and List of Components .....	7
5.4- Electrical Drawing.....	10
6-BOILER PACKAGING .....	12
7-FLUES .....	13
7.1- Flue Sizes .....	13
7.2- Flue Types.....	13
7.3- Distances for Placement of Flues .....	14
8-INSTALLATION .....	15
8.1- Selection of Installation Location of Device .....	15
8.2- Independent Operation from Ambient Air (Type C) .....	16
8.3- Mounting the Boiler .....	16
9 - CONNECTIONS.....	17
9.1- Condensate Discharge Connection .....	17
9.2- Gas and Water Connections.....	18
9.3- Electrical Connection.....	19
9.4- Room Thermostat .....	20
9.5- Outdoor Sensor .....	21
9.6- Room Thermostat and Outer Air Sensor Connection .....	22
10- COMMISSIONING, USE AND TURNING OFF THE BOILER .....	23
11- CONTROL PANEL .....	24
12- GAS CONVERSION .....	27
13- ERROR CODES VE DESCRIPTIONS .....	27
14- USEFULL INFORMATION ON PRODUCT.....	30
15- ANNEXES .....	31
16-INSTALLATION TEMPLATE .....	32
17- ERP GUIDE.....	35
17.1- Technical Specifications Table.....	35
17.1- CE Marking .....	36
17.2- Product Information Sheet (ErP) .....	36
17.3- Package information card stating the central heating energy efficiency of the package.....	37
18-REMOVAL INFORMATION.....	39
18.1- Unpacking the New Device.....	39
18.1- Compliance with AEEE Regulation and Disposal of Waste Product.....	39

## 1. INTRODUCTION

First of all, we would like to thank you for choosing E.C.A. brand.

E.C.A. Proteus Premix condensing boilers have been designed for an efficient, safe and comfortable central heating and hot water requirement. The Proteus Premix condensing boilers can possibly use natural gas or LPG according to the desired fuel preference.

**HM Model:** It is designed for both Central Heating (CH) and Domestic Hot Water (DHW).

**HCH Model:** It is designed for Central Heating (CH).

**HST Model:** It is designed for both Central Heating (CH) and Domestic Hot Water (DHW). Boiler connection must be used for Domestic Hot Water (DHW) requirement.

The assembly and usage information of 14/20/24/28/30/35/42/45 kW Proteus Premix condensing boilers are available in this manual. Detailed information have been provided in the guide regarding the technical specifications of the devices, selection of the boiler location, fitting its water, gas, flue and electric supply connections, gas conversion, maintenance information and resolution of possible failures. Please carefully read the manual in order to benefit from all the features of your device.

Keep all the documents provided by your device in order to refer when required.

## 2. GUARANTEE AND SERVICE

- The appliance has guarantee period against faulty workmanship or material in condition that the instructions and precautions in this manual must be obeyed. The service operations and general maintenance must be carried out only qualified person.
- The warranty certificate must be registered by Service in the installation day.
- Your appliance needs not any repairs if operated according to this manual. For assistance for additional information, consult qualified person, installer or gas supplier.

## 3. DEFINITIONS OF SYMBOLS

The following symbols have been placed at required points in the text in order to draw attention to significant points regarding the usage and assembly of the device. The meanings of the symbols have been specified below.



Indicates that the situation that can only be interfered by qualified person.



Explanations containing information that should be considered by the user.



**CAUTION:** It means that you may suffer from material damage or slight personal injury.  
**DANGER:** It means that you may suffer from sever personal injury.

## **4. SAFETY RULES AND WARNINGS**

### **4.1. Safety Instructions**

#### ***When a gas leak is found or suspected;***

- Turn off the gas valve of the boiler and the valves of all other devices operating with gas.
- Shut off the stove, oven and similar appliances to put their flame out.
- Do not light matches, lighter etc, and stub out your cigarette.
- Ventilate the environment by opening doors and windows.
- Do not ever touch the buttons and plugs of your electrical appliances.
- Turn off the gas valves in the apartment and building entrance.
- Do not use the phones at places where the gas leak is suspected.
- Call your qualified person as soon as possible.
- Do not place and use flammable and explosive liquid or materials around the boiler.
- Keep materials such as water, foam away from electrical connections during operations such as cleaning, gas leak test etc.
- Do not lay the LPG container down
- Do not block air vents, openings made in the walls of the room which provide fresh air to the installation room.

### **4.2. Water Systems & Gas Supply Line**

- Before installation of the boiler, the water systems (CH & DHW circuit) and gas supply line must be completed in accordance with the relevant regulations and standards by user.

### **4.3. Gas Type Conversion**

- The appliances should be purchased depending on operating gas type. In case of a demanding gas type conversion, this is made with charge.
- Gas type conversion should be performed by the authorized service. Gas leak test should be made after the conversion operation.
- The self-adhesive conversion label must be placed on the boiler after gas type conversion.

### **4.4. Installation**

- The boiler must be installed in accordance with national and local requirements, gas safety regulations, relevant standards and this manual by qualified installer.
- The appliance should be mounted against a closed wall.
- The appliance should not be positioned having direct contact to steam, detergent or gases.
- Any change of flue position must not be made without consulting qualified person.
- Sunlight can cause color change on the exterior of your device over time.
- The device must be installed in indoor spaces under normal conditions. However, it can be operated in a suitable cabinet in places such as garage, open balcony. Please consult E.C.A. for proper cabinet sizes.
- If device is located in an unheated area, it should be connected to mains, switched on, and pressure of installation should be within operation range so that freeze protection would be activated. Even if device is OFF position, freeze protection stays activated.

### **4.5. Boiler Start Up**

- Boiler start up must be performed certainly by qualified person.
- Gas Type (Natural Gas / LPG), gas supply pressure (mbar), maximum DHW operating water pressure (bar) and electricity supply voltage on the information plate must be suitable with mains supply conditions. This is checked by qualified person.
- After boiler start up, you should request information about operating the boiler and safety precautions from qualified person.



**CAUTION:** The 2-amp bipolar fuse with a minimum contact opening of 3 mm must be used in the electrical connection of the boiler.

## 4.6. Usage and Maintenance

- Read carefully instructions and precautions in this manual against wrong usage which causes unsafe conditions.
- The boiler should be checked and serviced for general maintenance once a year. Maintenance and service operations must be carried out only qualified person.
- Only a damp cloth should be used for cleaning the outer surface of the boiler and then the surfaces should be dried completely. Do not use chemical substances or solutions which cause rust and scratches in your appliances.



**CAUTION:** This device is not intended to be used by persons with physical, sensory or mental disabilities (even children) or persons with inadequate experience and knowledge, unless the person responsible for the safety of the device provides supervision and management of the use of the device. Children must be kept under surveillance to ensure that they do not play with the device. Cleaning and user maintenance should not be done by unattended children.



**CAUTION:** This device is not intended for use by persons (including children) who are low physical or sensory and mental capacity and inexperienced persons without informing and supervising the use of the device by responsible persons. Ensure that children do not play with the appliance.



**CAUTION:** If device is used incorrectly or for other than its intended use, it may present a life hazard and may cause material damage to the product and its surroundings.



**CAUTION:** This appliance can be used by children aged from 8 years and above and persons with reduced physical, sensory or mental capabilities or lack of experience and knowledge if they have been given supervision or instruction concerning use of the appliance in a safe way and understand the hazards involved.

## 5. PRODUCT

### 5.1. General Specifications

Control panel is ergonomic and easy to use. The Proteus Premix condensing combi boiler with elegant plastic control panel and advanced LCD screen provides ease of use and service. On a LCD display with black instrument panel; you can see the operating state icons, heating circuit and operating water adjustment values, the fault / failure codes and the heating water pressure. With the safety systems available in your device, safety of both you and your device are fully ensured.

These safety systems;

- Flame Failure Safety System
- Boiler Over-Heat Safety System (95 ° C)
- DHW (Domestic Hot Water) Over-Heat System (71 ° C)
- High Water Pressure Protection System (3 bar)
- Low Water Pressure Protection System (0.4 bar) for 42-45kW (0.8 bar)
- Low Voltage Protection System (170 VAC)
- Thermal Accumulation Protection System (with by-pass circuit and “pump over-run”)
- Frost Protection System for both CH and DHW circuit
- Domestic Hot Water Flow Control
- Pump Anti-sticking Function
- 3 Way Valve Anti-sticking Function
- Automatic Air Vent
- Expansion Vessel
- Maintenance Reminder Function (Yearly)
- Anti-legioner Protection(70°C)(only for HST Model)

## 5.2. Notations of Product

NOTATION	DESCRIPTION
Proteus Premix 14/20/24/28/30/35/42/45 kW HM	Proteus Premix Hermetic Monotermic Condensing Boiler
Proteus Premix 14/20/24/28/30/35/42/45 kW HCH	Proteus Premix Hermetic Central Heating Condensing Boiler
Proteus Premix 14/20/24/28/30/35/42/45 kW HST	Proteus Premix Hermetic Storage Tank Condensing Boiler

Table 1

## 5.3. Detailed View and List of Components

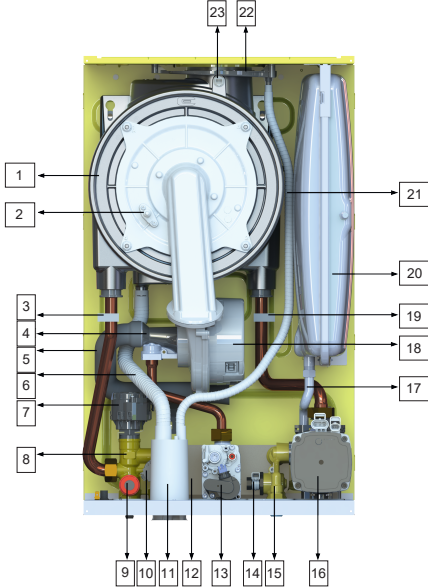

Figure 1.1

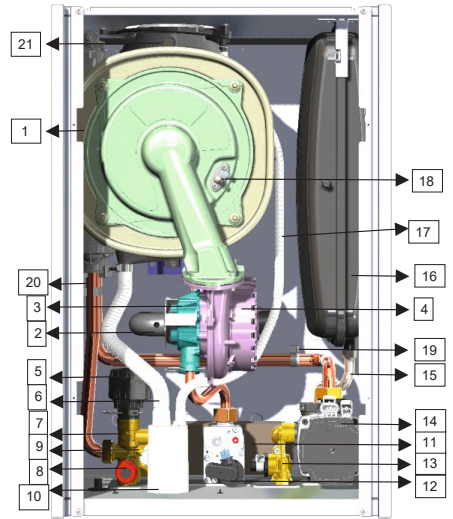

Figure 1.2

\*Component internal layouts may vary depending on models.

1. Main Exchanger
2. Ignition Electrode
3. Flow Water Temperature Sensor
4. Venturi
5. Suppressor
6. Condensate Hose
7. Motorized Valve
8. Flow Manifold
9. Safety valve
10. Water Pressure Sensor
11. Siphon
12. Plate Heat Exchanger
13. Gas Valve
14. Turbine
15. Return Manifold
16. Pump
17. Flexible Connection Hose
18. Fan
19. Return Water Temperature Sensor
20. Expansion Tank
21. Rainwater Hose
22. Rainwater Collection Container
23. Flue Gas Sensor

1. Main Exchanger
2. Suppressor
3. venturi
4. Fan
5. Motorized Valve
6. Condensate Hose
7. Flow Manifold
8. 3 Bar Safety Valve
9. Pressure sensor
10. Siphon
11. Plate Heat Exchanger
12. Gas Valve
13. Return Manifold
14. Pump
15. Expansion Tank Hose
16. Expansion Tank (12 liters)
17. Rainwater Hose
18. Ignition Electrode
19. Return Water Temperature Sensor
20. Flow Water Temperature Sensor
21. Flue Gas Sensor

### 5.3.1. HM Model

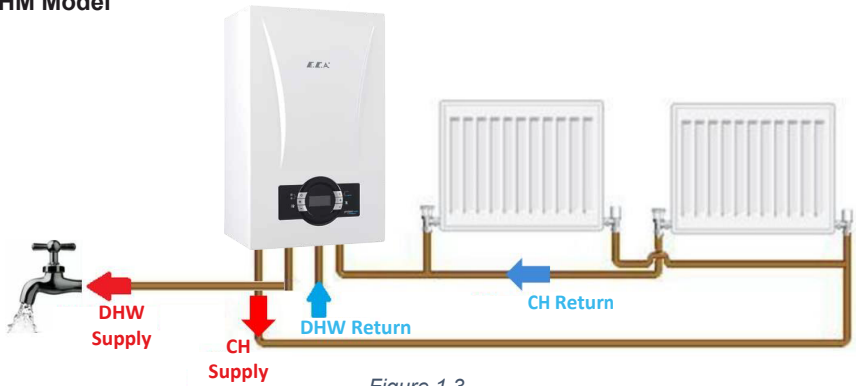

Figure 1.3

### 5.3.2. HCH Model

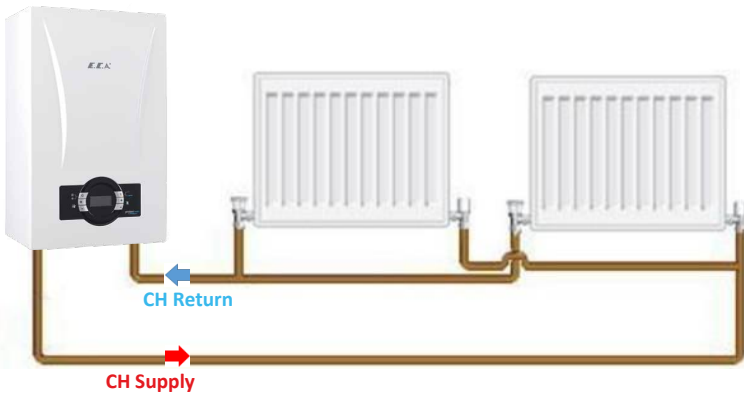

Figure 1.4

### 5.3.3. HST Model

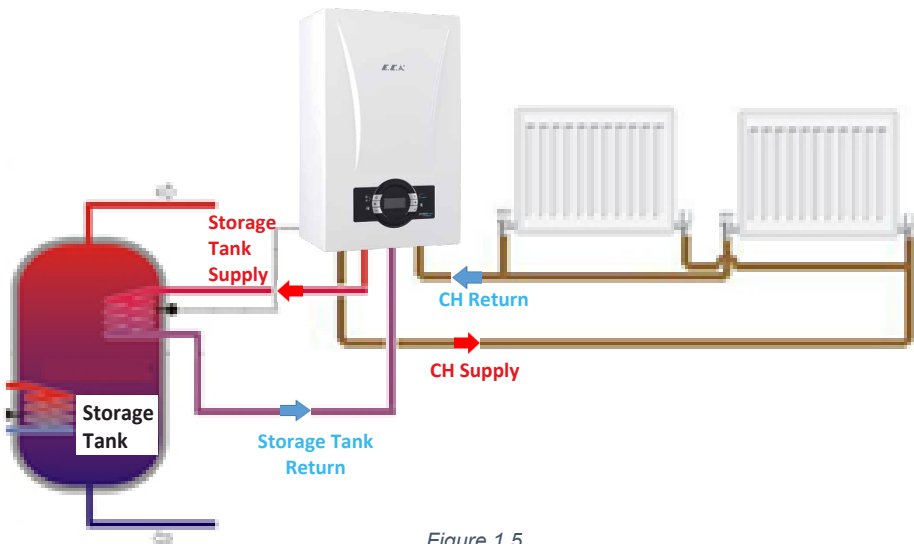

Figure 1.5



## 5.4. Electrical Drawing

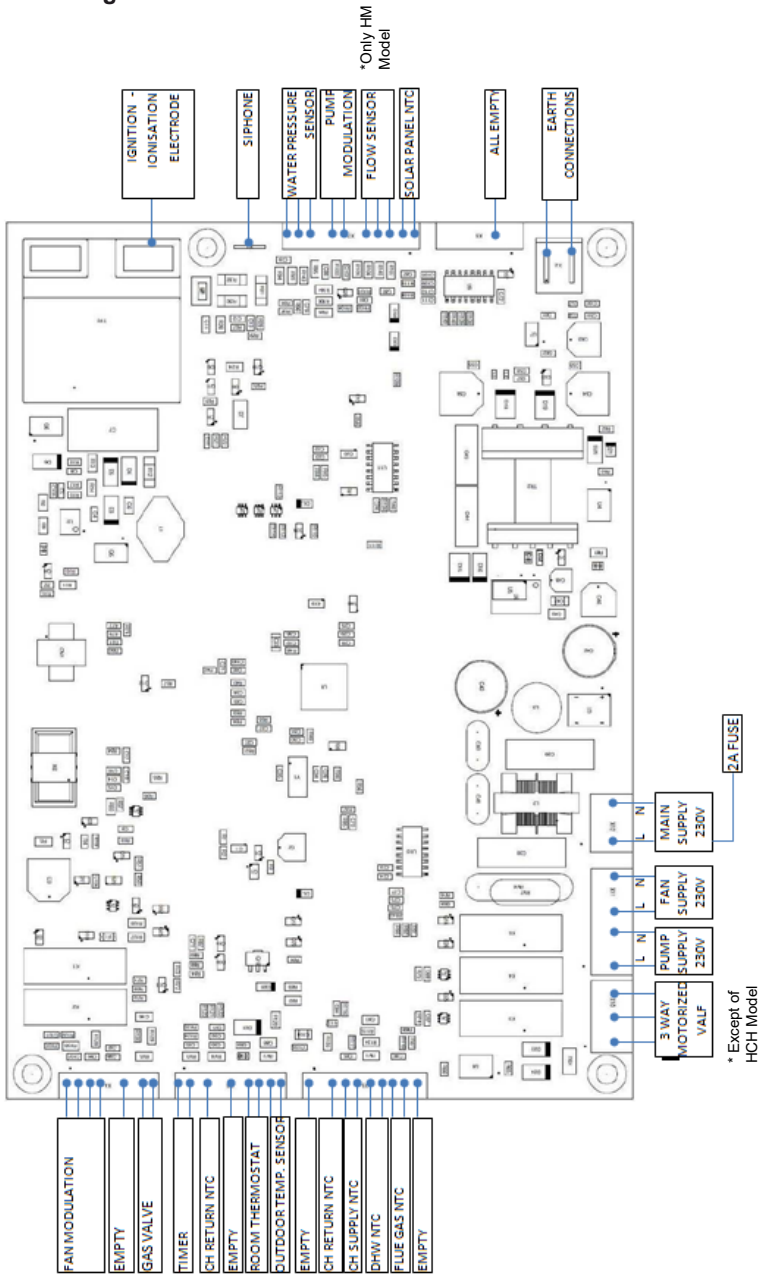

Figure 2.1 Versiyon A

\*Boiler sensor in HST model

# Electrical Drawing

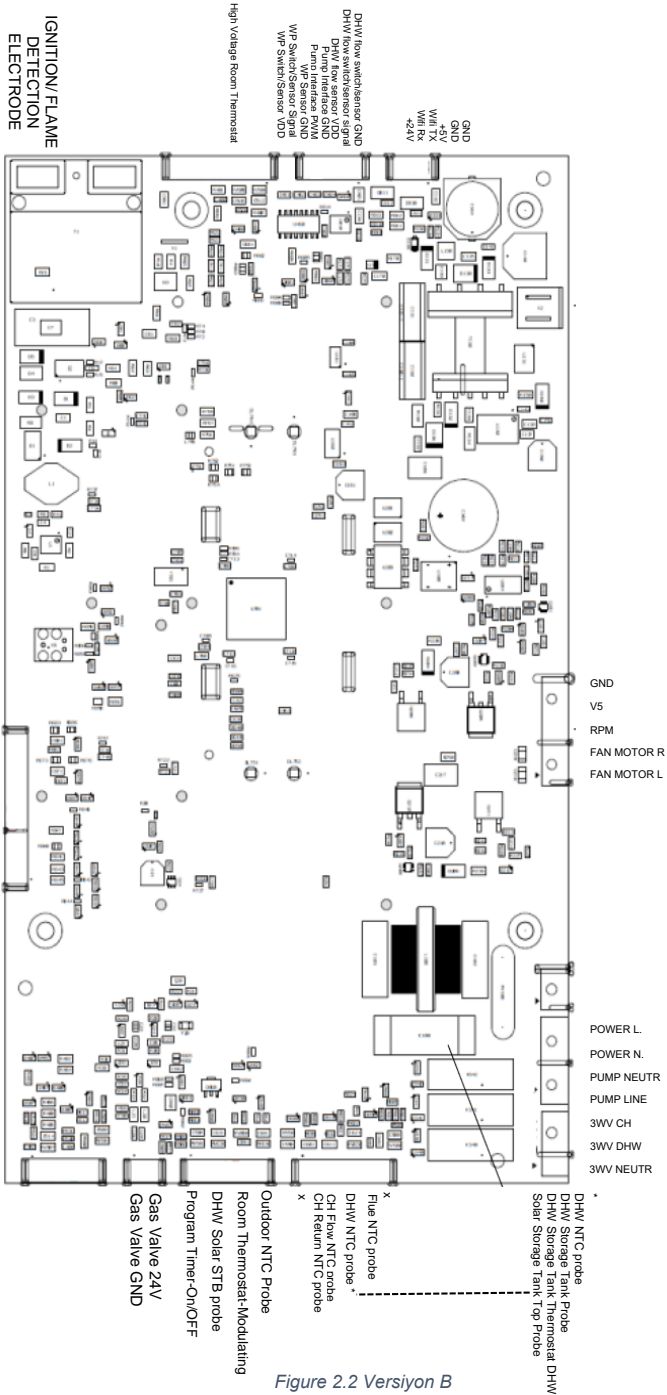

Figure 2.2 Versiyon B

# Electrical Drawing

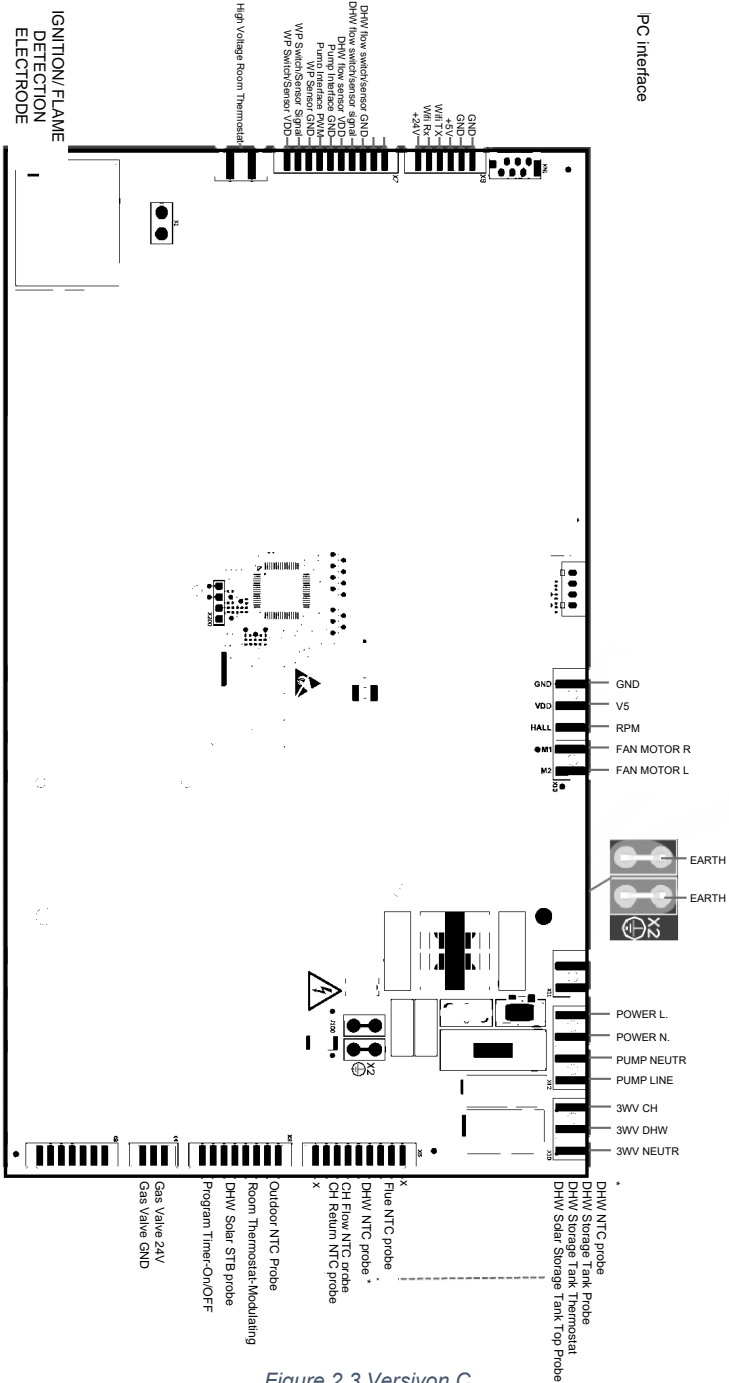

Figure 2.3 Versiyon C

## 6. BOILER PACKAGING



**CAUTION:** Attention must be paid to warning on packaging regarding handling and storage.

- The device is delivered in a cardboard box with dimensions of 735 x 345 x 490 (HxWxD) mm, supported by upper and lower styrofoam. (746 x 395 x 515 (HxWxD), valid for 42-45 kW.)

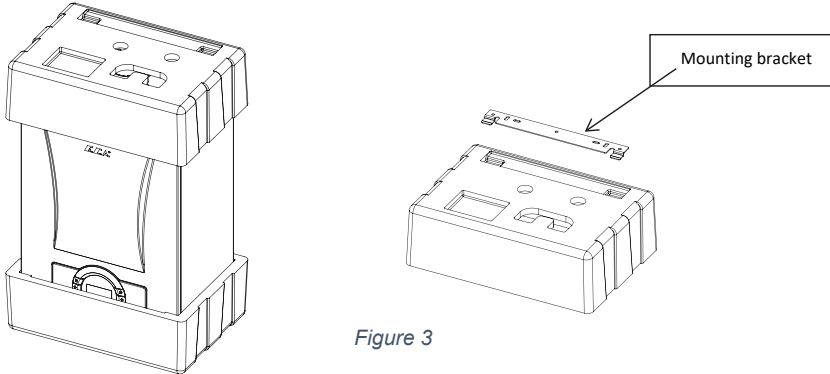

Figure 3

-Parts required for installation of the device (wall bracket, 5 gaskets for HM and HCH and 6 gaskets for HST water and gas connections, 3 anchors and 3 fixing screws) are placed on the top styrofoam.

-The hermetic chimney set is delivered in a cardboard box separate from the device. The standard hermetic flue set (Ø60/100) consists of the following parts (Figure 4).

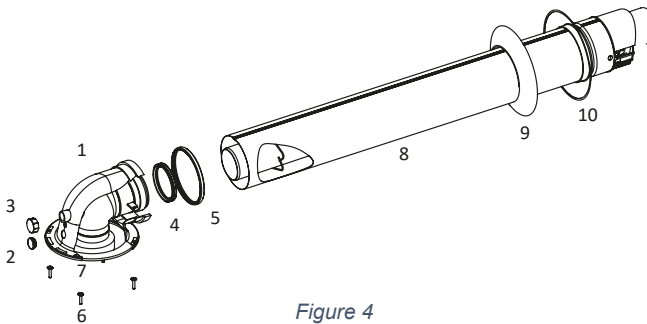

Figure 4

1. 90° Elbow	6. Flange Screws
2. Exhaust Gas Tap	7. Flange Gaskets
3. Air Inlet Tap	8. Flue Exhaust Terminal
4. Sealing Gasket Ø60	9. Inner Wall Connection Flange
5. Sealing Gasket Ø 100	10. Outer Wall Connection Flange (EPDM)

Table 2

## 7. FLUES

### 7.1. Flue Sizes

Flue gas connections between the boiler and the flue terminal must be made using original components specially designed for the condensing boiler to ensure that the device operates efficiently and correctly.

Flue gas pipes and fittings of non-condensing boilers can not be used for exhausting gases from condensing boilers. In the horizontal concentric flues, the exhaust gas pipe (the inner pipe) facing outwards should be inclined upward and the fresh air pipe (outer pipe) should be inclined downward. When the original flue set is installed parallel to the ground, the exhaust gas pipe is automatically inclined upwards.

Equivalent length for each 90° elbow: 1 m

Equivalent length for each 45° elbow: 0.5 m

### 7.2. Flue Types

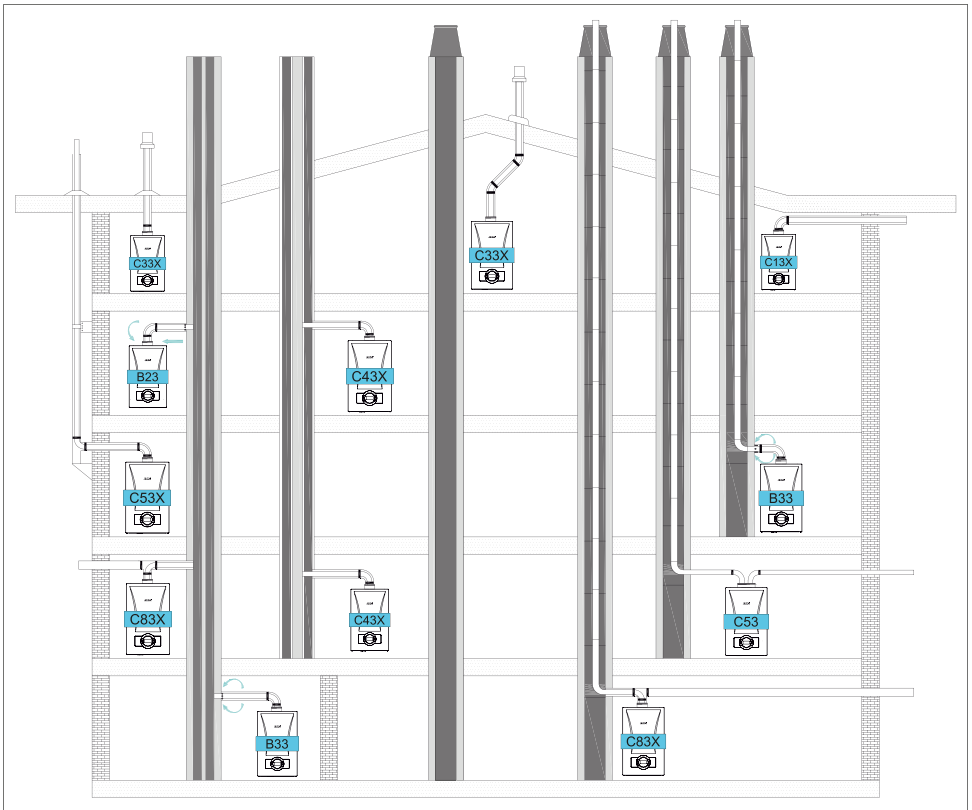

Figure 5

### 7.3. Distances for Placement of Flues

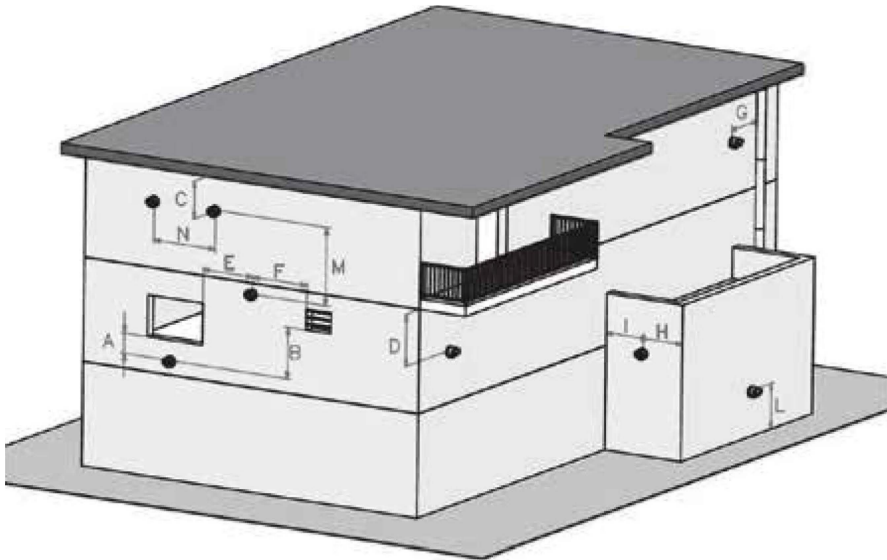

Figure 6

POSITION	DISTANCE (cm)	POSITION	DISTANCE (cm)
A-Below a windows	60	G- Next to vertical or horizontal pipe	60
B- Below an air vent	60	H- Below the distance grille from the outside of the building	30
C- Below rain channel	30	I- Distance from the inner corner of the building	100
D- Under the balcony	30	L- From the ground or from the floor	180
E- Next to a window	40	M- Vertical distance of two flue outlets	150
F- Next to an air grill	60	N- Horizontal distance of two flue outlets	100

Table 3

Places where it is undesirable to install the chimney outlet of type C (hermetic) devices are stated in the following articles:

- Passages and corridors,
- Narrow eaves gaps,
- Ventilation and light spaces of buildings,
- Inner parts of balconies,
- Elevator shafts,
- Vents that provide fresh air to other units,
- In places that may be directly exposed to wind resistance.

Underground, basement etc. chimneys of the products installed in the spaces; It should be installed in a way that it will not endanger living spaces and that no person can intervene. If such an installation is not possible, the chimney outlet should be extended to the roof.

## 8. INSTALLATION

### 8.1. Selection of Installation Location of Device

In addition to some restrictions given by TSE and authorized gas companies for the places where the device can be installed, the distances that must remain around the device for service, maintenance and use should be as shown in Figure 7.

Figure 7: Shows the minimum distances that the device must stay from the top and side facades (Dimensions are given in mm).

In order to carry out the service and maintenance of the boiler correctly, it is recommended that the installation be made in accordance with the minimum distances below. The position of the boiler must be checked in accordance with technical rules.

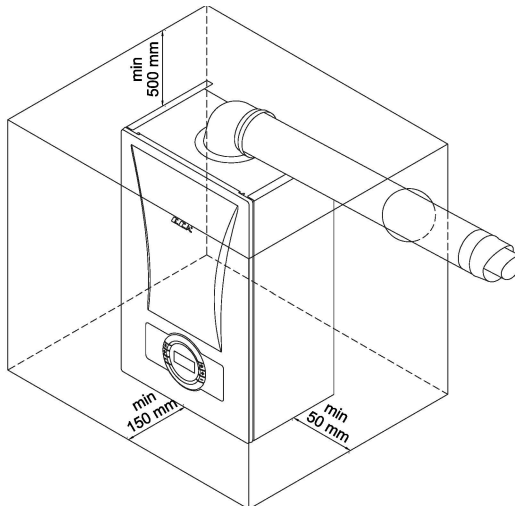

Figure 7



- The device can be used at altitudes up to 2000 m above sea level.



- There is no need to remove side panels in the combi boiler service operations. Minimum 50 mm clearances are given taking into consideration the share of possible side panel sheet changes.



- Do not install your boilers in locations that will be exposed to direct sunlight. Sunlight can cause color change on the exterior of your device over time. Ambient temperature of device's installation location should be between 5-35 °C.

- Since the outside temperature of the device does not rise above 85 °C at the maximum heating power, no special protective measures are required against the combustible construction materials and components.

## 8.2. Independent Operation from Ambient Air (Type C)



**DANGER:** The installation location of your condensing boiler and the flue gas connection must comply with the instructions specified by TSE authorized gas companies.



**DANGER:** Unapproved combustion air / flue gas flow pipes may pose a risk of injury. Only use the manufacturer's original combustion air / flue gas flow pipes. It is not appropriate to intervene in the original chimney kits (cutting, making additions, etc.).



**DANGER:** During installation, the combi boiler chimney set and its accessories must be fixed in a way to maintain their tightness, taking into account the effects and impacts that may come from outside. Otherwise, CO (Carbon monoxide) gas that will leak from the chimney connections will cause poisoning and pose a life-threatening risk.

- A chimney clamp should be used for each chimney and vertical section transition points, and a distance of less than 2 m should be left between two chimney clamps. The chimney system must be fixed rigidly to the wall with the chimney clamp.
- Type C (hermetic) devices are not suitable for outdoor installation. These devices must be installed inside the building.
- Even if Type C combi boilers are isolated from the environment they are located in, in case of any gas leakage, the place where they are installed must comply with the ventilation instructions required by TSE and authorized gas organizations.



**DANGER:** Do not block the air vents which provide fresh air to the installation room.

The chimney outlet terminal must be opened to an external environment where air inlet and flue gas outlet can be provided uninterruptedly.

- When determining the chimney exit location, the instructions specified by TSE and authorized gas organizations must be followed.
- In condensing combi boiler horizontal chimney kit applications, the chimney connection should be mounted in a way that slopes 2° or 3°degrees upwards to allow condensate water to return to the device.



Information

- The flue ducts are always wet.



Information

- Under cold or excessive humid weather conditions the water vapor inside the waste gas may condensate while leaving the flue.

## 8.3. Mounting the Boiler

Having determined the boiler location,

- Using the mounting template (Pages 31 - 33) included in the user manual of the device, the locations of the wall hanging bracket and the fixing screws of the mounting bracket are marked.
- After the marked areas are drilled, the wall hanging bracket and mounting bracket are securely fixed to the wall with the dowels and fixing screws included in the packaging of the device.
- Finally, the hanging bracket on the back surface of the boiler is placed on the hooks on the hanging bracket you mounted on the wall, and the boiler is hung on the wall.



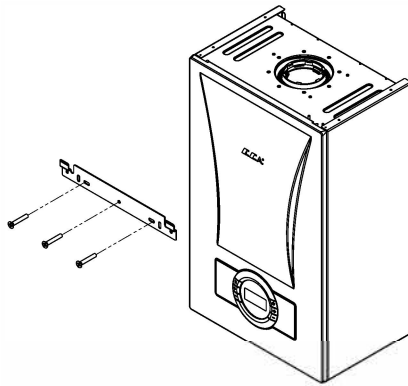

Figure 8

## 9. CONNECTIONS

### 9.1. Condensate Discharge Connection

**Information** In condensing combi boilers, condensation occurs during combustion. The amount of condensate varies depending on the operating conditions of the device. By consuming 1 m<sup>3</sup> of natural gas, a maximum of 1.7 liters of condensate occurs.

- Condensate must be connected to a drain using a plastic hose connected to the end of the siphon. The drain hose supplied with the device is recommended for drain connection. 1 cable tie should be added to the hose for fixing.
- If the discharge hose will be connected to a drain outside the building, insulation must be made if necessary to prevent the hose from freezing.
- The condensate drain hose and its connecting parts must be made of plastic material.
- To ensure good flow in the discharge hose, all horizontal hose connections should be made with a 2° and 3° downward inclination.



Figure 9

## 9.2. Gas and Water Connections

- Water and gas connections between the mounting bracket fixed on the wall and the boiler are mounted with the pipe group and nipple as shown in the figure.

### 9.2.1. HM Model

- a) CH flow  $\frac{3}{4}$ " (hot)
- b) DHW outlet  $\frac{1}{2}$ " (hot)
- c) Gas inlet  $\frac{3}{4}$ "
- d) DHW inlet  $\frac{1}{2}$ " (cold)
- e) CH return  $\frac{3}{4}$ " (cold)

- A valve suitable for their diameter should be placed on water and gas pipelines. Additionally, the domestic water pipe  
A strainer should be placed on the (1/2") inlet and (3/4") return lines of the heating pipe.  
- The hose coming out of the 3 bar safety valve must be connected to the waste water drain line.  
- The connection between the device and the indoor gas line must be made with a flexible connection element (flexible pipe).

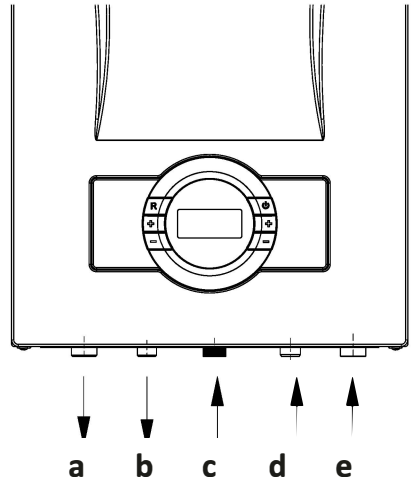

Figure 10

### 9.2.2. HCH Model

- a) CH flow  $\frac{3}{4}$ " (hot)
- b) Water filling line 1/2"
- c) Gas inlet  $\frac{3}{4}$ "
- d) CH return  $\frac{3}{4}$ " (cold)

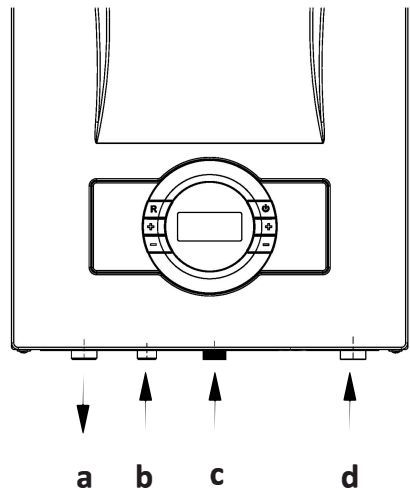

Figure 11

### 9.2.3. HST Model

- a) CH flow  $\frac{3}{4}$ " (hot)
- b) Boiler supply water (hot)
- c) Gas inlet  $\frac{3}{4}$ "
- d) Boiler return (cold)
- e) Installation Filling Line  $\frac{1}{2}$ "
- f) CH return  $\frac{3}{4}$ " (cold)

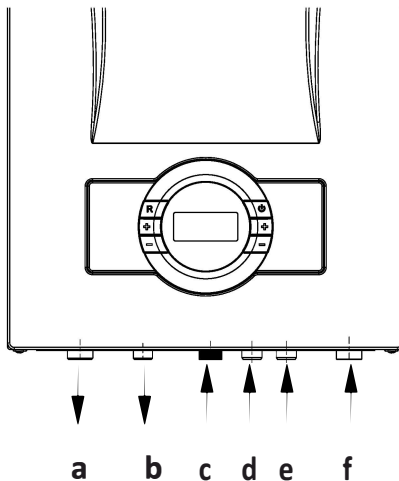

Figure 12

### 9.3. Electrical Connection

Electrical installation should be made according to the national and local instructions. The boiler must be earthed and a standard 230 VAC – 50 Hz supply is required.



**DANGER:** When connecting the device to electricity, care should be taken to ensure that there is no voltage on the electrical line.



**DANGER:** If the supply cable is damaged, it must be replaced by the manufacturer or its authorized service or an equally qualified person.



**CAUTION:** A 2 Ampere double pole fuse with a minimum contact opening of 3 mm must be used in the electrical installation connection of the boiler.



**CAUTION:** The electrical installation cable diameter (including insulation) in which the device will be installed must be at least 14 mm and the pipe diameter used must be at least 16 mm.

## 9.4. Room Thermostat

One of the optional room thermostats compatible with your device can be used to control the heating of the space.



E.C.A. Poly COMFORT  
200B Thermostat  
**7006903007**

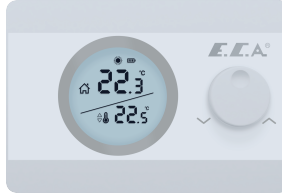

Poly Plus 100 Wireless  
Room Thermostat  
**7006903002**



E.C.A. Poly TOUCH  
400B Thermostat  
**7006903006**



E.C.A. Poly COMFORT  
200W Thermostat  
**7006903004**



E.C.A. Poly PURE  
100W Thermostat  
**7006903003**

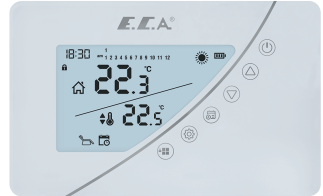

E.C.A. Poly TOUCH  
400W Thermostat  
**7006903005**



E.C.A. Circle 100 W  
On/Off Wireless  
Room Thermostat  
**7006903000**



E.C.A. Poly 100W  
On/Off Wireless  
Room Thermostat  
**7006903001**



E.C.A. Wireless  
Room Thermostat  
On/Off  
**7006907522**



E.C.A. Programmable  
Digital Room Thermostat  
-CM707  
**7006901313**

Figure 13

## 9.5. Outdoor Sensor

To connect the room thermostat or outdoor sensor to the device, the connections behind the control panel are used. For the room thermostat, the bridged cable connection on the back of the control panel is removed and the outer air sensor is connected to free sockets on the terminal.



- It can be provided as an option according to boiler models.
- It allows operation of combi boiler adjusted to outside temperature.

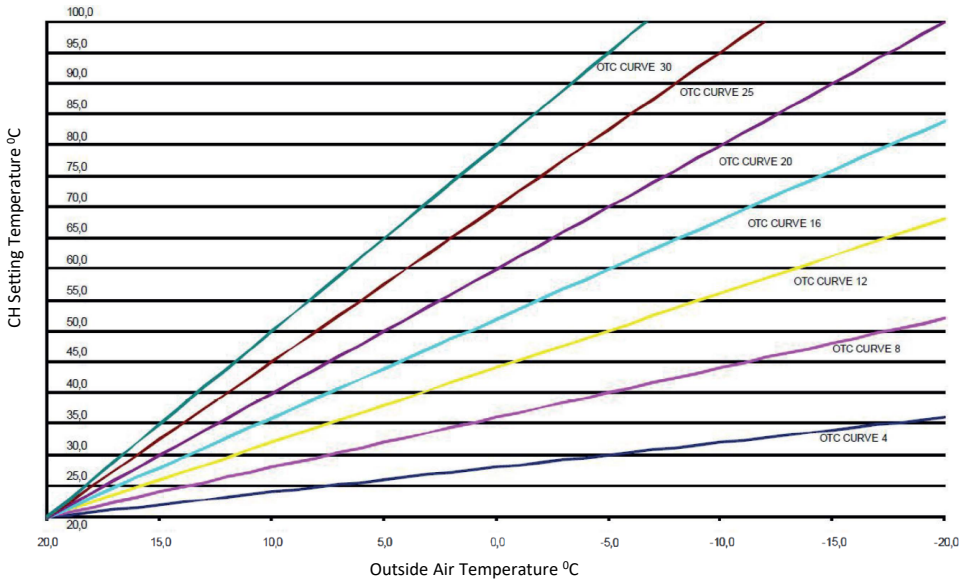
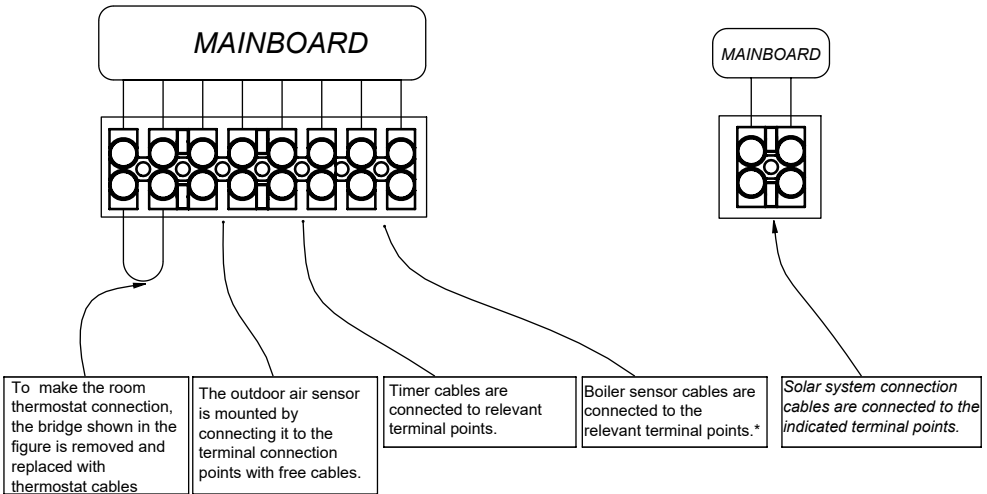

Figure 14

## 9.6. Room Thermostat and Outer Air Sensor Connection



\*This connection type is only valid for HST models.

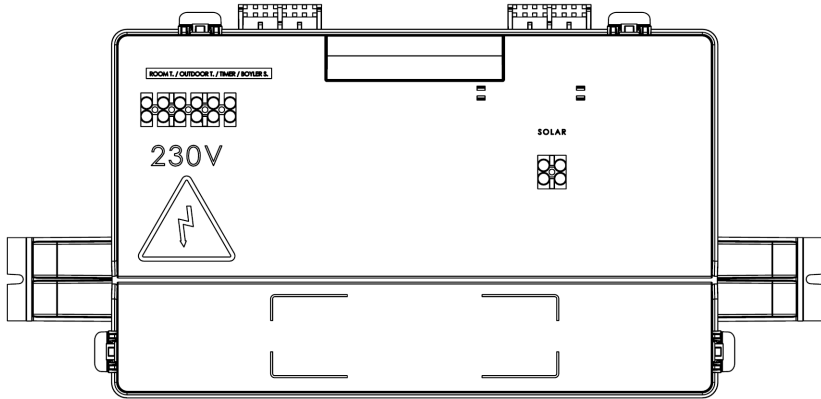

Figure 15

€ Cancel the bridge on the other side on room thermostat connection.

€ Only E.C.A. in your boiler. Room thermostats approved by authorized services should be used. Otherwise, it may cause your device to malfunction. No liability is accepted in such cases.



The connections of room thermostat, outdoor sensor and timer must be performed certainly by qualified person.

## 10. COMMISSIONING, USE AND TURNING OFF THE BOILER

### 10.1. Commissioning, Filling Water into Boiler and Heater Installation

- First of all, the boiler electrical connection is made. The electrical connection of the device must be connected to a grounded socket line that can provide sufficient voltage (230 VAC 50 Hz) for the device.
- All radiator valves are opened.
- The valves of the boiler's heating flow and return lines must be open. Please check.
- After these procedures, the filling valve is opened slowly and the water filling process is started. The filling process continues until 1.5 – 2 bar water pressure value is read on the LCD screen and then the filling valve is closed.
- When the water pressure exceeds 0.8 bar, the text “AP” will appear on the LCD screen and the boiler will switch to automatic air discharge mode. In this case, definitely wait 160 seconds without pressing “RESET”. Wait for the ongoing mode to complete.
- Check the water pressure on the pressure gauge frequently and make sure it is between 1.5 - 2 bar when the system is cold. If the pressure drops frequently, there is a water leak in the system. In this case, it is necessary to call a plumber.

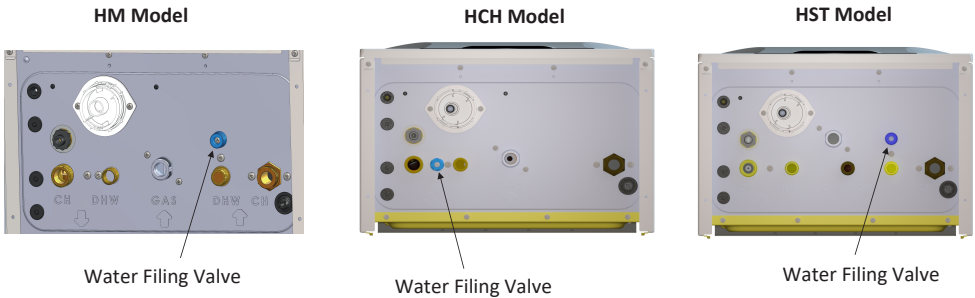

Figure 16



**ATTENTION :** Always close the water filling valve, the installation water may leak and damage the environment.

- To discharge air out of CH installation, purgers of the radiator is loosened and air is discharged until water comes out of radiators. This procedure is done for all radiators.
- Pressure is checked again on LCD screen. The filling valve is opened and again pressure is raised to 1.5 - 2 bar level.
- Radiator purgers are checked again to see if there is any air left inside of heating installation. For full efficient heating, all air must be discharged.
- Finally, check for any leaks in the radiator and piping.



**ATTENTION:** In order to prevent calcification of the heat exchanger, you are advised not to use well water, natural spring water instead of mains water.

- Check the domestic water installation by opening the hot water tap. Check for any leaks in the plumbing pipes.
- The flue group must be assembled from original parts in accordance with the instructions.
- The gas line must be checked and open by the authorized gas company. After all these procedures are completed, the authorized service must be called to put the device into operation.
- The first start-up of the device must be done by an authorized service.
- At the end of the first operation of the device after its installation, ask the authorized service for information about the operation of the device and safety devices.

## 10.2. Using the Device

### 10.2.1. Switching off the Device

You can switch off the boiler by holding down the ON/ OFF button for 3 seconds. LCD light will be OFF after 1 minute.

**Anti-freeze function remains active.**

## 11. CONTROL PANEL

### 11.1. Functions of Buttons

The control panel consists of the relevant elements as shown in figure 17 below.



Figure 17 - Control Panel

#### 1 Position Selection Button

The position can be changed by pressing the position selection button once to change between the winter mode and the summer mode. If the button is pressed for 3 seconds, the device will switch into "standby" position. It will suffice to press the button once to get the device in operation position.

#### 2 Reset Button

Main functions:

- Exit from lockout error (EXX)
- ECO mode activation
- Comfort mode activation

When your device malfunctions, the fault code will start flashing on the screen. There are two types of faults: permanent (EXX) and temporary (FXX) faults. When a permanent error occurs (EXX), the error must first be corrected in order for the error code to disappear from the LCD screen, and then the device can return to normal operation by pressing the "Reset" button once. If it is in temporary still state (FXX), the error cannot be cleared from the LCD screen with the "Reset" button. When this error condition is corrected, the error code automatically disappears from the LCD screen. When the device first starts up, it will start in Comfort mode.

While operating in Comfort mode, pressing the "Reset" button once will switch the device to Eco mode. Then, when the "Reset" button is pressed again, the device will switch to Comfort mode.



### 3 Domestic Hot Water Increase Temperature Button

The temperature of the domestic water can be increased up to 65 °C thanks to the domestic water temperature increase button.

### 4 Central Heating Water Increase Temperature Button

Thanks to the heating circuit heating temperature increase button, the temperature of the heating water in the heating circuit can be increased up to 80°C.

### 5 Domestic Hot Water Decrease Temperature Button

The temperature of the domestic water can be decreased down to 30 °C thanks to the domestic water temperature decrease button.

### 6 Central Heating Water Decrease Temperature Button

The temperature of the heating water can be decreased down to 30 °C thanks to the heating water temperature decrease button.

## 11.2. LCD Screen

LCD screen display icons described here below.

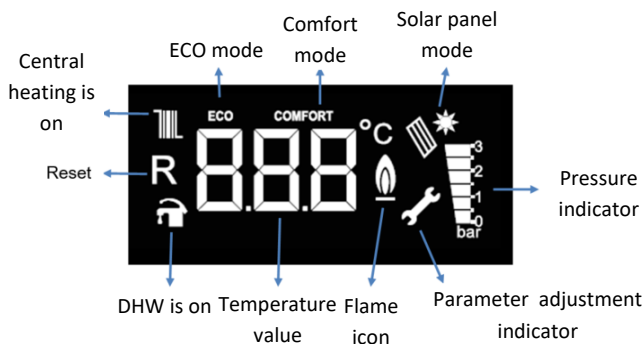

Figure 18 - LCD Screen Icons

**11.2.1. Flame Icon:** When operating between 0% and 50% capacity range, the icon is displayed on the LCD screen as single bar, whereas it is displayed as two bars when operating between 50% -100% capacity range.

**11.2.2. Pressure Indicator:** The LCD display shows 0-0,5-1-1,5-2-2,5-3 bar water pressure values. The values other than these ones are not displayed. Only when filling after F37 (Low water pressure error) fault, the pressure value is displayed in the temperature value section.

## 11.3. Operation Functions

### 11.3.1. Standby (OFF Mode):

The mode where device can be set to standby mode. In this mode, no requests for heating water and domestic water can be made. To activate the OFF mode, it is necessary to keep button no. 1 (position selector) pressed for 3 seconds continuously. When -OFF- is displayed on screen, mode is activated.

**11.3.2. Air Discharge Mode (AP Mode):** It is the process that the device automatically performs to evacuate the air in the central heating installation for 160 seconds. During this mode, "AP" appears on the screen. The circulation pump runs for 15 seconds and stops for 5 seconds every 20 seconds. The three-way valve motor also changes position between CH-DHW every 40 seconds. The situation in which this mode is applied is listed below.

- Once the device is powered for the first time or after the electricity has been switched off and on,
- After the reset operation following the overheating fault (E03),
- After elimination of high water pressure (F40) or low water pressure (F37) error,



Information

Do not press 'RESET' while AP mode is active.

**11.3.3. Winter mode-Radiator Heating:** If the device in the standby position is set to the winter position, the appliance will heat the water in the heating circuit until the domestic water is needed. In the winter mode, both the tap and the radiator icon are displayed on the LCD screen.

When a request for heating is made for radiator, radiator icon flashes (once/second), tap icon stays fixed. When a request for domestic water is made, tap icon flashes (once/second), radiator icon stays fixed. In this mode, radiator heating circuit's temperature can be set between 30-80 °C. For under floor heating applications, the temperature range can be set between 30-45 °C.

**11.3.4. Summer Mode:** If the device in the OFF position is set to the summer position, the device will only respond to the domestic hot water demands. In summer mode, the tap symbol appears fixed on the LCD screen, the radiator icon does not appear. When the domestic hot water is heating request, the tap symbol flashes (1 time / second). In this mode, the domestic hot water temperature can be adjusted between 30-65 °C.

**11.3.5. Comfort Mode:** The standard operating mode of the device is Comfort mode. By pressing the "Reset" button, Eco-Comfort modes can be switched. When Comfort mode is active, "Comfort" icon is displayed on the LCD screen. Comfort mode is only for radiator heating circuit. It has no effect on use of domestic water circuit. In this mode, the device responds to fast heating demands by running in modulation.

**11.3.6. ECO Mode:** By pressing the "Reset" button, Eco-Comfort modes can be switched. When Eco mode is active, "Eco" icon is displayed on the LCD screen. Eco mode is only for radiator heating circuit. It has no effect on use of domestic water circuit. This mode allows savings on fuel by performing on-off operation.



**11.3.7. Maintenance Reminder Mode:** This is the mode that reminds you that it is time for annual maintenance of the device. When this mode is active, the word "ASE" appears on the screen and the device meets its heating needs without any interruption. When you see the text "ASE", you need to use E.C.A. for annual maintenance. Contact authorized services.

**11.3.8. Anti-Frost Mode:** During the winter season, when the installation water temperature drops below 6°C, the frost protection function is activated and your device continues to operate until the installation water outlet rises to 15°C. In order for the frost protection function to work, the following conditions must be checked and met by the customer.

- The power supply of the device must be switched on.
- The gas valve and radiator valves must be open.
- Water pressure of system should be at appropriate level.
- The anti-freeze function helps protect your device, it does not protect your installation.
- If device will not be operated for a while in places where there is risk of freezing, then it is necessary to drain the water or to use an anti-freeze agent.

## 12. GAS CONVERSION



**Gas conversion operation from LPG to natural gas or from natural gas to LPG should be performed by authorized service. If the user requests gas transformation after purchase of the device, it is subject to a fee.**

For the gas conversion process, a conversion kit is required. The conversion kit includes 1 gas orifice, 1 klingerite gasket and 1 gas conversion label. Procedure for gas conversion;

- Installation of parts in the conversion kit
- Gas adjustment
- Parameter change (P01: 0 for natural gas, P01:1 for LPG)

## 13. ERROR CODES VE DESCRIPTIONS

Error Code	Error Type	Possible Cause	Troubleshooting
E01	Ignition Fault	No gas connection for boiler.	1- Check that the gas valve is open. 2-Check if there is gas in installation. 3- Press reset button. 4- If the error is still present (or persists) after reset, notify authorized service of E.C.A.
E02	False flame indication	It is triggered if flame is detected in the burner while gas valve is closed.	1- Press reset button. 2- If the error is still present (or persists) after reset, notify authorized service of E.C.A.
E03	High limit temperature protection	It will occur if the temperature of ingoing and outgoing water exceeds 90 C.	1- Check that water valves of boiler installation are open. 2- If the boiler triggers this error in winter mode, check that at least 1 radiator is open. 3- Press reset button. 4- If the error is still present (or persists) after reset, notify authorized service of E.C.A.
E05	No frequency feedback from fan after 1 minute	Failure of fan or fan cable	1- Press reset button. 2- If the error is still present (or persists) after reset, notify authorized service of E.C.A.
E06	Fan Signal Error	The speed value measured from the fan is not within the specified range for 60 seconds.	1- Press reset button. 2- If the error is still present (or persists) after reset, notify authorized service of E.C.A.
E07	Heat Exchanger High Temperature Error	High Flue Gas Temperature	1- Press reset button. 2- If the error is still present (or persists) after reset, notify authorized service of E.C.A.

E08	Flame circuit failure	The electronic card may be failed.	1- Press reset button. 2- If the error is still present (or persists) after reset, notify authorized service of E.C.A.
			1- Change the electronic card. 2- If the error continues (or repeats) after the reset, E.C.A. Notify the authorized service.
E09	Valve feedback error	The gas valve may be failed.	1- Press reset button. 2- If the error is still present (or persists) after reset, notify authorized service of E.C.A.
E12	EEPROM check fail	The electronic card may be failed.	1- Press reset button. 2- If the error is still present (or persists) after reset, notify authorized service of E.C.A.
E16	Error on Temperature Sensor for Outgoing Water	No temperature is detected by temperature sensor for outgoing water.	1- Press reset button. 2- If the error is still present (or persists) after reset, notify authorized service of E.C.A.
E17	Error on Temperature Sensor for Returning Water	No temperature is detected by temperature sensor for returning water.	1- Press reset button. 2- If the error is still present (or persists) after reset, notify authorized service of E.C.A.
E18	Temperature Sensor Error	The temperature change on the temperature sensor is too large (30°C)	1- Press reset button. 2- If the error is still present (or persists) after reset, notify authorized service of E.C.A.
E21	Analog-Digital Converter (ADC) Error	The electronic card may be failed.	1- Press reset button. 2- If the error is still present (or persists) after reset, notify authorized service of E.C.A.
E33	Error on Temperature Sensor for Returning Water	The return water temperature sensor is in short or open circuit state.	1- Press reset button. 2- If the error is still present (or persists) after reset, notify authorized service of E.C.A.
E35	Error on Temperature Sensor for Outgoing Water	The outgoing water temperature sensor is in short or open circuit state.	1- Press reset button. 2- If the error is still present (or persists) after reset, notify authorized service of E.C.A.
E54	Siphon full	When the contact in the siphon is closed via the water because of full siphon the error is set.	1- Press reset button. 2- If the error is still present (or persists) after reset, notify authorized service of E.C.A.
E80	Supply return swap test	Supply and return sensor are swapped.	1- Press reset button. 2- If the error is still present (or persists) after reset, notify authorized service of E.C.A.
E82	Flame failure (more than 3 flame failures in 4 minutes)	Flame detection problem	1- Press reset button. 2- If the error is still present (or persists) after reset, notify authorized service of E.C.A.

E83	Ignition Circuit Error	7	1- Press reset button. 2- If the error is still present (or persists) after reset, notify authorized service of E.C.A.
70		@  #	1- Press reset button. 2- If the error is still present (or persists) after reset, notify authorized service of E.C.A.
708	Ionization component error	Problem on ionization circuit components	1- Press reset button. 2- If the error is still present (or persists) after reset, notify authorized service of E.C.A.
7	k k 7	h k	1- Notify authorized service of E.C.A.
7	Gas Valve Circuit Error	The electronic card may be failed.	1- Notify authorized service of E.C.A.
7	Electronic Card Failed	Electronic card software error.	1- Notify authorized service of E.C.A.
7	O o	The temperature change on the temperature sensor is too large (30°C)	V - # "
F37	Low Water Pressure Fault	It occurs when water pressure sensor detects a relatively low water pressure (0.4 bar) for your device.	1- Check water pressure in heater installation of your device. 2- Fill the system with water until the pressure reaches 1.5-2 bar (device will eliminate error when the pressure is over 0,8 bar). 3- Check your valves and installation against leaks. 4- If the problem is still present (or persists), notify authorized service of E.C.A.
F39	Outer Air Sensor Fault	Outer air sensor might be defective.	1- Press reset button. 2- If the error is still present (or persists) after reset, notify authorized service of E.C.A.
F40	High Water Pressure Fault	It occurs when water pressure sensor detects a relatively high water pressure (3,3 ±0,3 bar) for your device.	1- Check water pressure in heater installation of your device. 2- Turn off the device and restart it. 3- If the error is still present (or persists) after reset, notify authorized service of E.C.A.
F41	Water Filling (Auto) Running	Automatic water willing is continuing	1- Notify authorized service of E.C.A.
F42	Water Fillin (Auto) Not Completed	Water filling valve may be failed or mains water pressure may be insufficient.	1- Notify authorized service of E.C.A.
F43	Low Water Pressure After Auto Water Filling Fault	Water filling valve may be failed or mains water pressure may be insufficient.	1- Press reset button. 2- If the error is still present (or persists) after reset, notify authorized service of E.C.A.

<b>F58</b>	<b>Flue Gas Lock Up at High Temperature</b>	Mainboard may be defective.	1- Press reset button. 2- If the error is still present (or persists) after reset, notify authorized service of E.C.A.
<b>F64</b>	<b>Fan protection error</b>	Fan feedback problem.	1- The fan cable is not plugged in or there may be a loose connection. Check the cables while there is no power to the device. 2- If the problem persists (or reoccurs), notify the E.C.A. authorized service.
<b>F81</b>	<b>Temperature sensor deviation test delay</b>	Temperature sensors might be defective.	1- Notify authorized service of E.C.A.

*Tablo 4*

## 14. USEFULL INFORMATION ON PRODUCT

### 14.1. Information on the Efficient Use of the Combi Boiler in Terms of Safety and Energy Consumption

Isolation of your building is extremely important. Energy saving is achieved at a considerable degree since the heat loss is lowest in houses with double-glazed windows and insulated walls.

- The use of thermostatic valves in your radiators ensures that the room temperature is constant or allows you to save money.
- Turning radiator valves lower levels in the rooms which will not be used for a long time and keeping the doors closed keeps fuel consumption low.
- If you use the program clock with your device, the combi boiler operates at the times you set and consumes less fuel.
- If you use your boiler with room thermostat, it keeps the boiler temperature at the level you set and thus allows less fuel consumption.
- Covering the radiator top and sides with furniture-like things negatively affects hot air circulation, thus prevents the environment from overheating and increases fuel consumption.
- If you will leave your device in operation late at night, keeping water temperature of the heating circuit at low levels will ensure saving.
- If you feel that the room temperature is high, the radiator valves should be closed instead of opening windows.

### 14.2. Clogging in Installation

- In old installations with iron pipes, usually clogging occurs short time after the device is commissioned.
- If clogging in installation is encountered with, then inhibitor (Sentinel X400, etc.) should be added to installation water.

Keep the outer casing of the boiler clean by wiping it with a soft damp cloth. Do not use harsh, abrasive cleaning agents.

Having your boiler serviced during the warranty period and periodically after the warranty period expires, once a year before the winter season, will ensure safe use, save fuel and extend the life of the device. The relevant maintenance times will be automatically reminded by the boiler.

Periodic maintenance must be carried out by E.C.A. Have it done by Authorized Services.

To ensure the longevity and safety of the device, use only original spare parts. E.C.A. will not be liable for any damage that may occur to the device or surrounding objects and living things as a result of maintenance carried out by unauthorized service and persons. will not be responsible.

## 15. ANNEXES

### 15.1. Characteristic curve of water pressure height of the pump (pump head-flow rate)

15-60 (for 14-20-24-28-30 kW models)

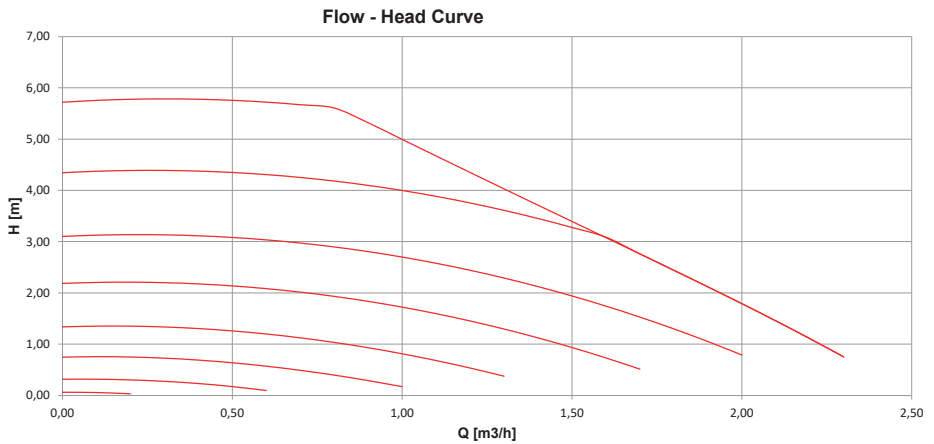

15-70 (35-42-45 kW)

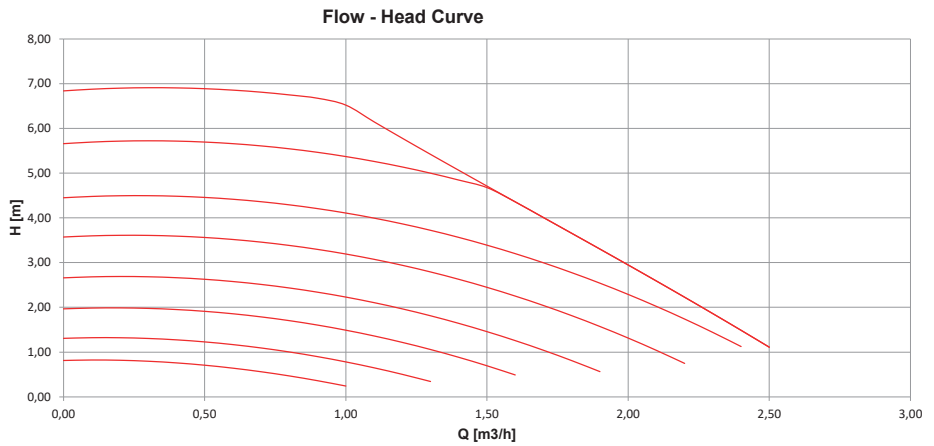

## 16. INSTALLATION TEMPLATE

### 16.1. HM Model

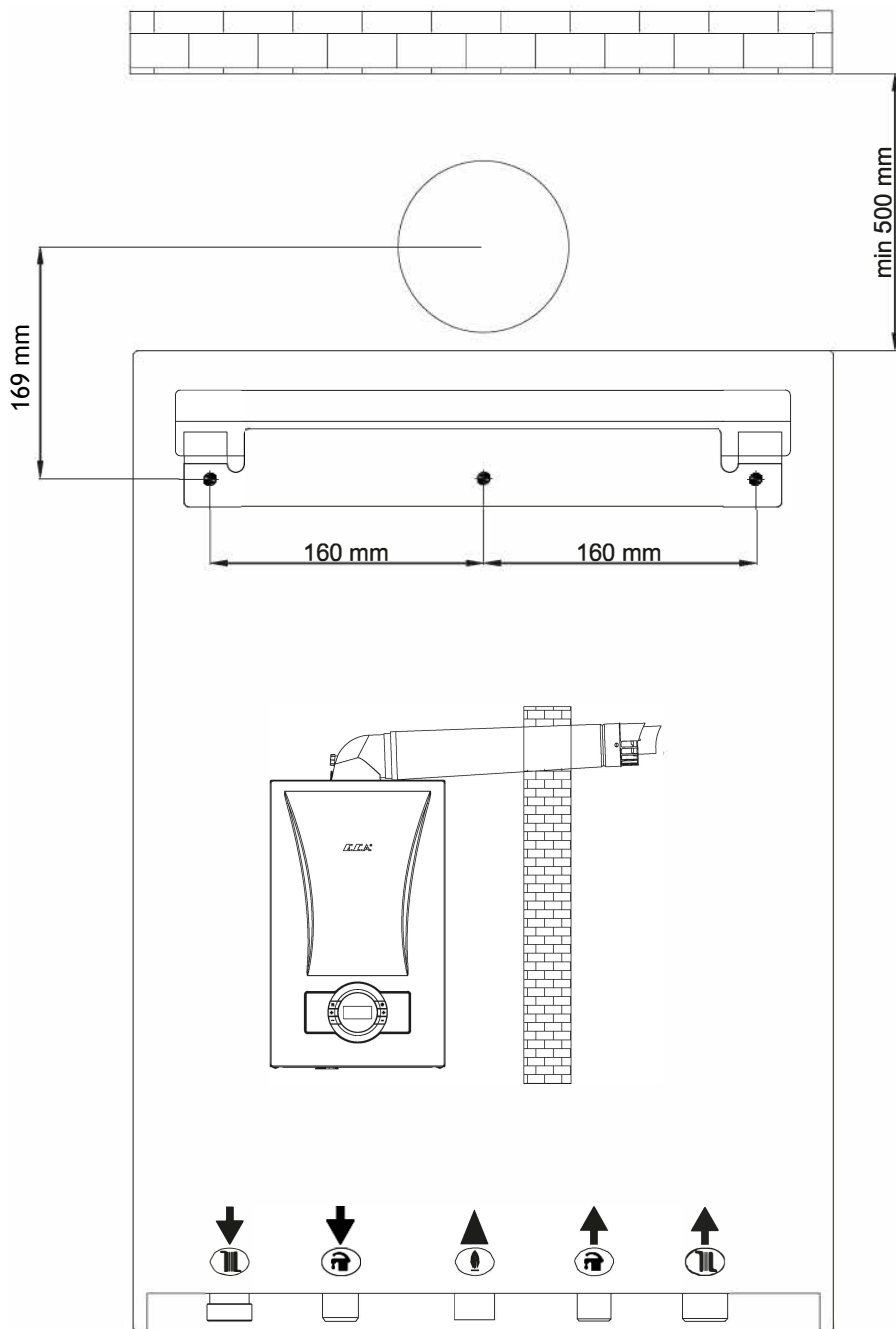



16.2. HCH Model

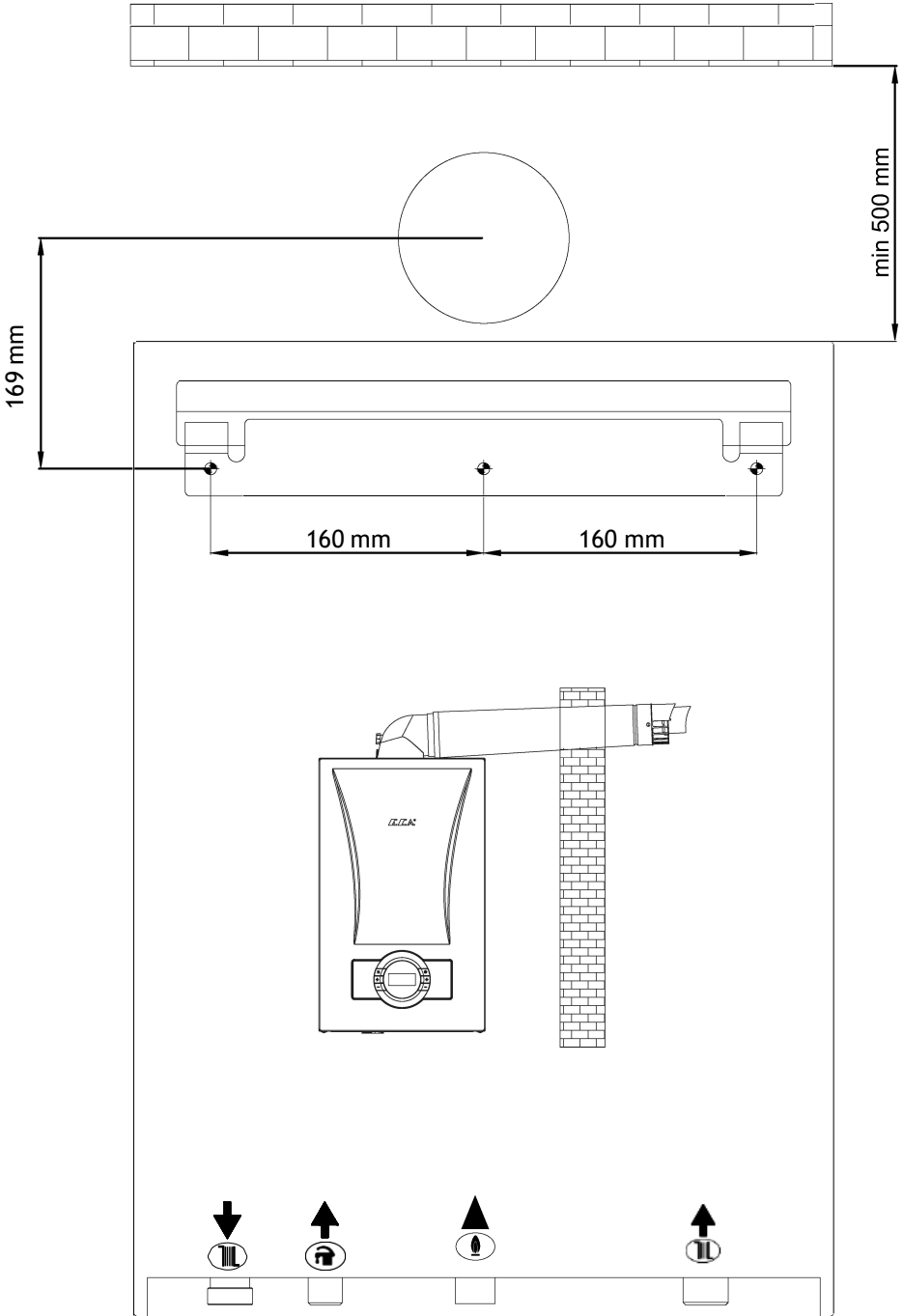

16.3. HST Model

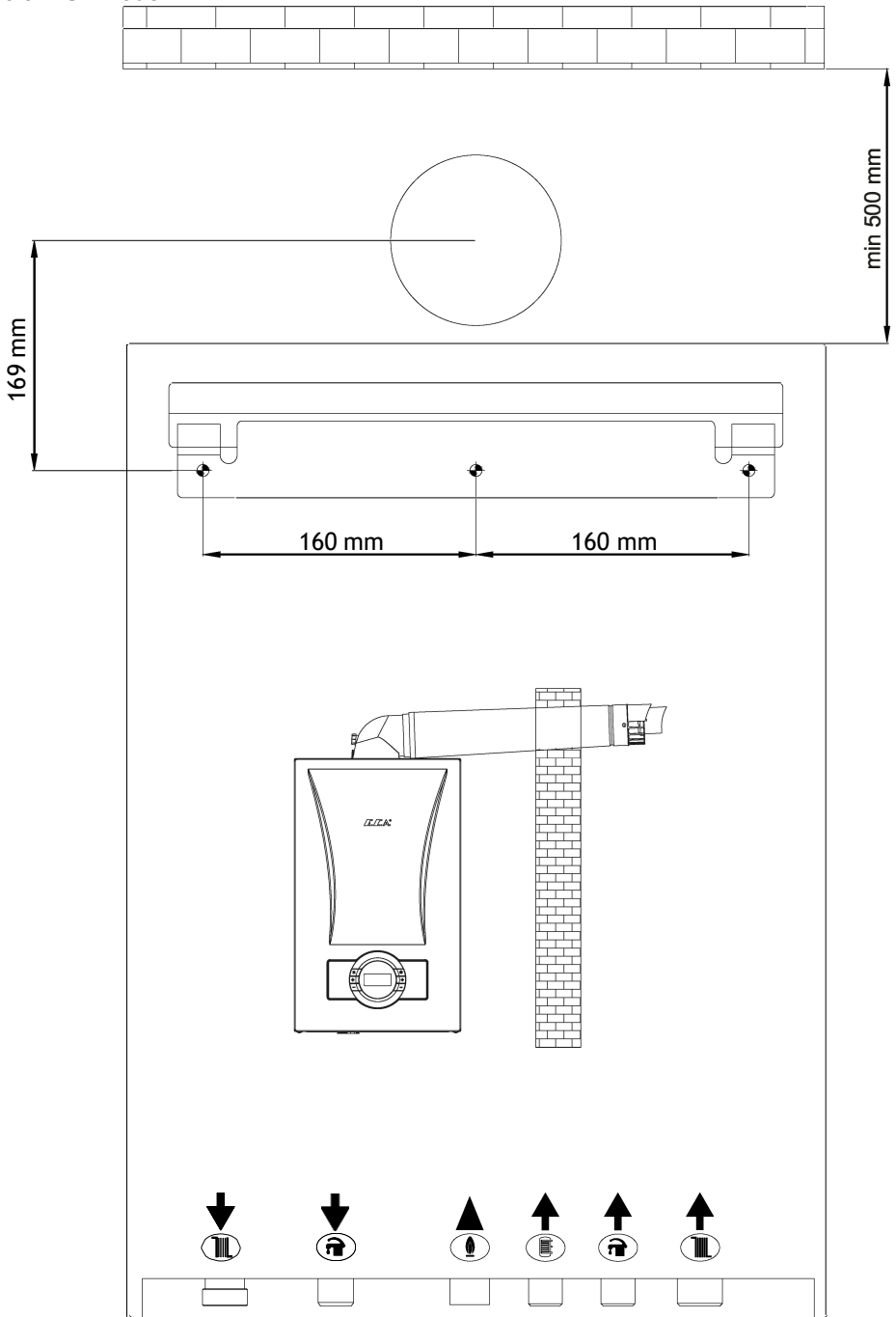

# 17. ERP GUIDE

## 17.1. Technical Specifications Table

Product Type	Unit	PROTEUS	PROTEUS	PROTEUS	PROTEUS	PROTEUS	PROTEUS	PROTEUS	PROTEUS	
		PREMIUM 14	PREMIUM 20	PREMIUM 24	PREMIUM 28	PREMIUM 30	PREMIUM 35	PREMIUM 42	PREMIUM 45	
		HM-HCH-HST	HM-HCH-HST	HM-HCH-HST	HM-HCH-HST	HM-HCH-HST	HM-HCH-HST	HM-HCH-HST	HM-HCH-HST	
Gas Category		I2H, I3P, I2Esi, I2E(S), I12L3P, I12H3P, I12ELL3P, I12Esi3P								
Flue Type		C13(X), C33(X), C43(X), C53(X), C63(X), C83(X), B23, B33								
Gas Input Pressure (Natural Gas-G20)	mbar	20								
Gas Input Pressure (Natural Gas-G25)	mbar	20/25								
Gas Input Pressure (LPG-G31)	mbar	37/50								
<b>Capacity-Efficiency</b>										
Min. Heating Power - (60°C min)	kW	5,6	5,6	6	7	7,4	8,2	8	9	
Max. Heating Power - 80/60°C	kW	14,1	20,2	24,5	28	30	35	39	42,8	
Min. Heating Power - (30°C min)	kW	6,7	6,7	6,3	7,2	7,7	9	9,6	10,2	
Max. Heating Power - 50/30°C	kW	15	22,2	25,4	28,7	30,8	35,3	42	47	
Min. Heat Input (min)	kW	6,2	6,2	6,3	7,1	7,6	8,9	8,6	9,5	
Max. Heat Input (max)	kW	14,5	20,7	25,2	28,5	30,5	35,9	40	43,7	
<b>Gas Consumption</b>										
Natural Gas (@Min-Max Capacity)	m <sup>3</sup> /h	0,65-1,53	0,65-2,2	0,66-2,66	0,76-3,02	0,81-3,25	0,94-3,79	0,86-4,26	0,95-4,65	
Propane (@Min-Max Capacity)	kg/h	0,51-1,2	0,51-1,7	0,51-1,98	0,59-2,26	0,63-2,46	0,74-2,87	0,67-3,23	0,74-3,53	
NO <sub>x</sub> Class		6	6	6	6	6	6	6	6	
<b>Central Heating</b>										
Min. Water Pressure	bar	0,4	0,4	0,4	0,4	0,4	0,4	0,8	0,8	
Max. Water Pressure	bar	3	3	3	3	3	3	3	3	
Operation Range (Radiator Heating)	°C	30-80	30-80	30-80	30-80	30-80	30-80	30-80	30-80	
Operation Range (Underfloor Heating)	°C	30-45	30-45	30-45	30-45	30-45	30-45	30-45	30-45	
Max. Limit Temperature	°C	90	90	90	90	90	90	90	90	
<b>Domestic Hot Water (*f)</b>										
Min. Flow Rate for Operation (*f)	L/min	2,5 (±%10)	2,5 (±%10)	2,5 (±%10)	2,5 (±%10)	2,5 (±%10)	2,5 (±%10)	3 (±%10)	3 (±%10)	
Min. Flow Rate for Closing (*f)	L/min	2 (±%10)	2 (±%10)	2 (±%10)	2 (±%10)	2 (±%10)	2 (±%10)	2 (±%10)	2 (±%10)	
Max. Flow Rate (*f)	L/min	10 ±%15 (ΔT = 34,7°C)	10 ±%15 (ΔT = 34,7°C)	10 ±%15 (ΔT = 34,7°C)	12 ±%15 (ΔT = 33,5°C)	12 ±%15 (ΔT = 35,8°C)	14 ±%15 (ΔT = 35,8°C)	20 ±%15 (ΔT = 30°C)	21,7 ±%15 (ΔT = 30°C)	
Min. Water Pressure (*f)	bar	0,4	0,4	0,4	0,4	0,4	0,4	0,4	0,4	
Max. Water Pressure (*f)	bar	10	10	10	10	10	10	10	10	
Operation Range (*f)	°C	30-65	30-65	30-65	30-65	30-65	30-65	30-65	30-65	
Max. Limit Temperature (*f)	°C	71	71	71	71	71	71	71	71	
<b>General</b>										
Electrical Supply	V AC-Hz	230 VAC-50 Hz								
Electrical Consumption (Max-HE Pump)	Watt	65	80	85	110	130	165	170	180	
Protection Class		IPX4D								
Expansion Vessel	L	8							12	
Weight (Net)	kg	28,5	28,5	28,5	30	30	32	36		
Dimensions (HxWxD)	mm	678*410*288							325*444*670	
<b>Flue Lengths</b>										
C13 – 60/100 Max.	m	10	10	10	10	10	10	10	12	
C13 – 80/125 Max.	m	20	20	20	20	20	20	20	22	
C33 – 60/100 Max.	m	10	10	10	10	10	10	10	12	
C33 – 80/125 Max.	m	20	20	20	20	20	20	20	22	
C43 – 60/100 Max.	m	10	10	10	10	10	10	10	12	
C53 – 60/100 Max.	m	10	10	10	10	10	10	10	12	
C83 – 80/80 Max.	m	28	28	28	28	28	28	30	30	
C83 – 80/80 Min.	m	3	3	3	3	3	3	4	4	
B23 – 80 Max.	m	28	28	28	28	28	28	30	30	
B33- 60/100 Max.	m	10	10	10	10	10	10	12	12	
<b>Emission Values</b>										
CO <sub>2</sub> ratio (@max-G20)	%	9,2 ± 0,2	9,2 ± 0,2	9,3 ± 0,2	9,5 ± 0,2	9,5 ± 0,2	9,5 ± 0,2	9,0±0,2	9,0±0,2	
CO <sub>2</sub> ratio (@min-G20)	%	8,7 ± 0,2	8,7 ± 0,2	8,7 ± 0,2	8,9 ± 0,2	8,9 ± 0,2	8,9 ± 0,2	8,4±0,2	8,4±0,2	
CO <sub>2</sub> ratio (@max-G31)	%	10,4± 0,2	10,4± 0,2	10,4± 0,2	10,6 ± 0,2	10,6 ± 0,2	10,6 ± 0,2	10,1±0,2	10,1±0,2	
CO <sub>2</sub> ratio (@min-G31)	%	9,6 ± 0,2	9,6 ± 0,2	9,6 ± 0,2	9,9 ± 0,2	9,9 ± 0,2	9,9 ± 0,2	9,5±0,2	9,5±0,2	
<b>Boiler Circuit (*g)</b>										
Operation Range (*g)	°C	30-65	30-65	30-65	30-65	30-65	30-65	30-65	30-65	
Max. Limit Temperature (*g)	°C	85	85	85	85	85	85	85	85	

(\*f) Applies to HM models.

(\*g) Applies to HST models.

Table 5

## 17.2. CE Marking

 The CE mark certifies that the products meet the essential requirements of the applicable regulations in line with the declaration of conformity. The manufacturer can be consulted for a declaration of conformity.

## 17.3. Product Information Sheet (ErP)

The product data presented below complies with the requirements of EU regulations 811/2013 and 813/2013 to supplement directives 92/42/EU and 92/42/EEC.

CE PIN Number: 0085CS0133

Product Data	Symbol	Unit	PROTEUS PREMIX 14 HM-HCH-HST	PROTEUS PREMIX 20 HM-HCH-HST	PROTEUS PREMIX 24 HM-HCH-HST	PROTEUS PREMIX 28 HM-HCH-HST	PROTEUS PREMIX 30 HM-HCH-HST	PROTEUS PREMIX 35 HM-HCH-HST	PROTEUS PREMIX 42 HM-HCH-HST	PROTEUS PREMIX 45 HM-HCH-HST
Condensing boiler			Yes	Yes	Yes	Yes	Yes	Yes	Yes	Yes
Low-temperature boiler(*b)			No	No	No	No	No	No	No	No
B1 boiler			No	No	No	No	No	No	No	No
Cogeneration Space Heater			No	No	No	No	No	No	No	No
Combination Heater			Yes (for HM models) / No (for HCH and HST models)							
<b>Useful Heat Output</b>										
Rated heat output (*e)	Prated	kW	14	20	24	28	30	35	42	45
At rated heat output and high temperature regime (*a)	P4	kW	14,1	20,2	24,7	27,7	29,4	35	39	42,8
At 30% of rated heat output and low temperature regime	P1	kW	6,7	6,7	8,2	9,3	9,8	11,5	12,8	14
<b>Auxiliary Electricity Consumption</b>										
At full load	elmax	kW	0,02	0,029	0,04	0,051	0,056	0,066	0,05	0,08
At part load	elmin	kW	0,012	0,012	0,012	0,012	0,013	0,013	0,013	0,013
In Standby mode	PSB	kW	0,004	0,004	0,005	0,004	0,004	0,004	0,0021	0,0021
<b>Space Heating Efficiency</b>										
Seasonal space heating energy efficiency class			A	A	A	A	A	A	A	A
Seasonal space heating energy efficiency	ηs	%	92	92	93	93	93	93	92,21	92,18
At rated heat output and high temperature regime (*c)	η4	%	87,9	87,9	88,4	87,6	88,3	87,9	87,9	87,9
At 30% of rated heat output and low temperature regime (*d)	η1	%	97	97	98	97,9	97,9	97,9	97	97
<b>For Combination Heaters (*f)</b>										
Temperature application (*f)			Medium	Medium	Medium	Medium	Medium	Medium	Medium	Medium
Declared load profile (*f)			XL	XL	XL	XL	XL	XL	XL	XL
Water heating energy efficiency class (*f)			A	A	A	A	A	A	A	A
Water heating energy efficiency (*f)	ηwh	%	86	86	86	84	83	83	84	87,8
Daily fuel consumption (*f)	Qfuel	kWh	23,072	23,072	23,05	22,8	23,021	23,021	23,27	23,96
Annual fuel consumption (*f)	AFC	Gj	18	18	18	18	18	18	17	18
<b>Other Items</b>										
Standby Heat Loss	Pstby	kW	0,065	0,065	0,065	0,065	0,065	0,065	0,07	0,07
Ignition Burner Power Consumption	Pign	kW	0	0	0	0	0	0	0	0
Annual Energy Consumption	QHE	kWh	12267	17574	21315	24360	26100	30450	33930	37236
Daily Electricity Consumption	Qelec	kWh	0,21	0,21	0,21	0,22	0,24	0,212	0,15	0,15
Annual Electricity Consumption	AEC average	kWh	44	44	44	44	44	44	40	40
Sound Power Level	L <sub>WA</sub>	db(A)	49	49	49	49	50	52	53	53
Emission of Nitrogen Oxide	NOx	mg/kWh	31,18	30,89	29,14	22,88	27,17	34,33	33	34
Indication about ability working only during off-peak hours			No	No	No	No	No	No	No	No
Manufacturer	Emas Makina Sanayi A.Ş.									
Address of the Manufacturer	Mustafa Kemal Boulevard Organized Industrial Zone 3rd Section No: 13 45030 MANISA									

Table 6

(\*a) High-temperature regime means 60 °C return temperature at heater inlet and 80 °C feed temperature at heater outlet.

(\*b) Low temperature means for condensing boilers 30 °C, for low-temperature boilers 37 °C and for other heaters 50 °C return temperature (at heater inlet).

(\*c) High-temperature regime means 60 °C return temperature at heater inlet and 80 °C feed temperature at heater outlet.

(\*d) Low temperature means for condensing boilers 30 °C, for low-temperature boilers 37 °C and for other heaters 50 °C return temperature (at heater inlet).

(\*e) For heat pump heaters and combined heaters, the rated heat output Prated is the same as the standard load in heating mode Pdesignh. The rated heat output of a Psup auxiliary heating device is the same as the auxiliary heating power sup(Tj).

(\*f) valid for HM models.

## 17.4. Package information card stating the central heating energy efficiency of the package

### 17.4.1. Package Information - Combi Boiler

#### Seasonal Space Heating Energy Efficiency of the Combi Boiler (Table 7)

①

"I"

%

"I": The value of the seasonal heating efficiency of the primary central heater, expressed in %.

#### Temperature Controller

(Room Thermostat-Outdoor Air Sensor)  
From the temperature controller information sheet

Class I = 1%, Class II = 2%, Class III = 1.5%,  
 Class IV = 2%, Class V = 3%, Class VI = 4%,  
 Class VII = 3.5%, Class VIII = 5%

②

+

%

#### Additional Combi

Seasonal space heating energy efficiency in %

From the combi boiler information form

③

(

- "I" x 0,1

= ±

)

%

#### Solar Contribution

From the solar energy device data sheet

Collector size (m<sup>2</sup>)

Tank Volume (m<sup>3</sup>)

Collector Efficiency (%)

Tank Class  
 A\* = 0,95, A = 0,91,  
 B = 0,86, C = 0,83,  
 D - G = 0,81

④

( "III" x

+

"IV" x

) x 0,9 x (

/ 100 x

=

+

)

%

"III": Value of mathematical expression: 294/(11.Prated), where "Prated" refers to the preferred heater.

"IV": Value of mathematical expression: 115/(11.Prated), where "Prated" refers to the preferred heater.

(1) If tank rating is above A, use 0.95.

#### Additional Heat Pump Additive

From the heat pump data sheet

"II": The preferred factor for weighting the heat output of a package's optional and additional heaters is given in table 7.

⑤

(

- "I" x "II"

=

+

)

%

#### Solar Additive and Additional Heat Pump

Choose the smaller value

④

0,5 x

or 0,5 x

⑤

=

⑥

-

%

#### Seasonal Space Heating Energy Efficiency of the Package

⑦

)

%

#### Seasonal Space Heating Energy Efficiency Class of the Package

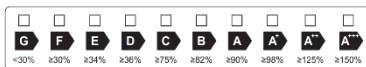

#### Are the Boiler and Additional Heat Pump Mounted with 35°C Low Temperature Radiating Devices?

From the Heat Pump Data Sheet ⑦

)

+

( 50 x "II" )

=

)

%

The energy efficiency of the products in the package provided for this data sheet (fiche) may not represent the actual energy efficiency when installed in a building, as the efficiency is affected by other factors such as heat loss in the distribution system and the sizing of the products depending on the size and characteristics of the building.

**Water Heating Energy Efficiency of Combination Heater (Table 8)**

Declared load profile:

①

"I"

%

**Solar Energy Device Contribution**

From the solar energy device data sheet

Auxiliary Electric

②

+

%

$$( 1.1 \times 'I' - 10\% ) \times 'II' - 'III' - 'I' =$$

**Water Heating Energy Efficiency of the Package under Average Climatic Conditions**

③

%

**Water Heating Energy Efficiency Class of the Package under Average Climatic Conditions**

	G	F	E	D	C	B	A	A'	A''	A'''
M	<27%	≥27%	≥30%	≥33%	≥36%	≥39%	≥55%	≥100%	≥130%	≥163%
L	<27%	≥27%	≥30%	≥34%	≥37%	≥50%	≥75%	≥115%	≥150%	≥188%
XL	<27%	≥27%	≥30%	≥35%	≥38%	≥55%	≥80%	≥123%	≥160%	≥200%
XXL	<28%	≥28%	≥32%	≥36%	≥40%	≥60%	≥85%	≥131%	≥170%	≥213%

**Water Heating Energy Efficiency of the Package under Average Climate Conditions**

Colder:  - 0,2 x  =  %

Hotter:  + 0,4 x  =  %

The energy efficiency of the products in the package provided for this data sheet may not represent the actual energy efficiency when installed in a building, as efficiency is affected by other factors such as heat loss in the distribution system and the sizing of the products depending on the size and characteristics of the building.

To evaluate the water heating energy efficiencies of combination heater, temperature control and solar device packages, the elements identified in Table 8 are included here:

- I: water heating energy efficiency value of the combination heater, expressed in %.
- II: Value of the mathematical expression (220.Qref)/Qnonsol. Here, Qref is taken from the product data sheet of the solar energy device in Annex VII and for the declared M, L, XL or XXL load profiles of the Qnonsol combination heater.
- III: Value of the mathematical expression (Qaux .25)/ (220.Qref) expressed as a %. Here, Qaux is taken from the product data sheet of the solar device and Qref is taken from Table 8 in Annex VII for the declared M, L, XL or XXL load profiles.

**Weighting of Combi Boilers**

**For Table 7 of this Annex, weighting of priority boiler space heater or boiler combination heater and auxiliary heater (\*)**

Psup / (Prated+Psup) <sup>(1)(2)</sup>	II, Package Without Hot Water Storage Tank	II, Package with Hot Water Storage Tank
0	0	0
0.1	0.3	0.37
0.2	0.55	0.70
0.3	0.75	0.85
0.4	0.85	0.94
0.5	0.95	0.98
0.6	0.98	1
≥ 0.7	1	1

- (1) Intermediate values are calculated by linear interpolation between two adjacent values.  
 (2) Prated is primarily associated with central heating and combination heater.

## 18. REMOVAL INFORMATION

### 18.1. Unpacking the New Device



Packaging protects your device against transport damage. All materials used in packaging are environmentally friendly and can be reused. Please help: Dispose of the packaging in a way that will not harm the environment. To obtain information about current troubleshooting methods and methods, please contact your authorized dealer or your municipality.

### 18.2. Compliance with AEEE Regulation and Disposal of Waste Product

Dispose of the packaging material in accordance with environmental rules.

This product is T.R. It does not contain harmful and prohibited substances specified in the "Regulation on the Control of Waste Electrical and Electronic Equipment" published by the Ministry of Environment and Urbanization.

It complies with AEEE regulations.

This product is manufactured from high quality parts and materials that are recyclable and reusable. Therefore, do not dispose of the product with household or other waste at the end of its service life. Take it to a collection point for the recycling of electrical and electronic equipment. Ask your local government about these collection points. Help protect the environment and natural resources by recycling used products. Before disposing of the product, for the safety of children, cut off the power plug and break the lock mechanism, rendering it inoperable.



## **PRODUCTION**

---

### **EMAS MAKINA SANAYI A.S**

Organize Sanayi Bölgesi 3. Kısım

Mustafa Kemal Bulvarı No: 13 45030

MANİSA / TÜRKİYE

Tel: +90 236 213 00 21

Fax : +90 236 213 08 59

email: [emas@emas.com.tr](mailto:emas@emas.com.tr) [www.emas.com.tr](http://www.emas.com.tr)

7006910378 - 2.0

