

**E.C.A.**<sup>®</sup>

**CitiusPremix**

**CITIUS PREMIX  
CONDENSING BOILER**

**CITIUS PREMIX 24/20/14 HM/HCH/HST**

**INSTALLATION AND USER  
OPERATING INSTRUCTIONS**



 E.C.A. Çaęrı Merkezi 444 0 322

## TABLE of CONTENTS

1-	INTRODUCTION .....	3
2-	GUARANTEE AND SERVICE .....	3
3-	DEFINITIONS OF SYMBOLS .....	3
4-	SAFETY RULES AND WARNINGS .....	4
4.1.	Safety Instructions .....	4
4.2.	Water Systems & Gas Supply Line .....	4
4.3.	Gas Conversion .....	4
4.4.	Installation .....	4
4.5.	Boiler Start Up .....	4
4.6.	Usage and Maintenance .....	4
5-	PRODUCT .....	5
5.1.	General Specifications .....	5
5.2.	Notations of Product .....	5
5.3.	Detailed View and List of Components .....	6
5.3.1.	HM Model .....	6
5.3.2.	HST Model .....	7
5.3.3.	HCH Model .....	7
5.4.	Technical Specifications .....	8
5.5.	Electrical Drawing .....	10
6-	BOILER PACKAGING .....	11
7-	FLUES .....	12
7.1.	Flue Sizes .....	12
7.2.	Flue Types .....	12
7.3.	Distances for Placement of Flues .....	13
8-	INSTALLATION .....	13
8.1.	Selection of Installation Location of Device .....	13
8.2.	Independent Operation from Ambient Air (Type C) .....	15
8.3.	Mounting the Boiler .....	15
9-	CONNECTIONS .....	16
9.1.	Condensate Discharge Connection .....	16
9.2.	Gas and Water Connections .....	17
9.2.1.	HM Model .....	17
9.2.2.	HCH Model .....	17
9.2.3.	HST Model .....	18
9.3.	Electrical Connection .....	18
9.4.	Room Thermostat .....	19
9.5.	Outdoor Sensor .....	20
9.6.	Room Thermostat and Outer Air Sensor Connection .....	21
10-	COMMISSIONING, USE AND TURNING OFF THE BOILER .....	22
11-	CONTROL PANEL .....	23
12-	ERROR CODES AND DESCRIPTIONS .....	26
13-	USEFULL INFORMATION ON PRODUCT .....	29
14-	ANNEXES .....	30
15-	INSTALLATION TEMPLATE .....	31
16-	ERP MANUAL .....	34
17-	DECLARATION OF CONFORMITY .....	37

## 1- INTRODUCTION

First of all, we would like to thank you for choosing E.C.A brand.

E.C.A. Citius Premix condensing boilers have been designed for an efficient, safe and comfortable central heating and hot water requirement. The Citius Premix condensing boilers can possibly use natural gas according to the desired fuel preference.

**HM Model:** It is designed for both Central Heating (CH) and Domestic Hot Water (DHW).

**HCH Model:** It is designed for Central Heating (CH).

**HST Model:** It is designed for both Central Heating (CH) and Domestic Hot Water (DHW). Boiler connection must be used for Domestic Hot Water (DHW) requirement.

The assembly and usage information of 14-20-24 kW Citius Premix condensing boilers are available in this manual. Detailed information have been provided in the guide regarding the technical specifications of the devices, selection of the boiler location, fitting its water, gas, flue and electric supply connections, maintenance information and resolution of possible failures. Please carefully read the manual in order to benefit from all the features of your device.

Keep all the documents provided by your device in order to refer when required.

\*In compliance with regulations regarding limited use of harmful materials used in electronic appliances.

\*Does not contain any polychlorinated biphenyl, asbestos and mercury.

## 2- GUARANTEE AND SERVICE

- The appliance has guarantee period against faulty workmanship or material in condition that the instructions and precautions in this manual must be obeyed. The service operations and general maintenance must be carried out only qualified person.

The warranty certificate must be registered by service in the installation day.

- Your appliance needs not any repairs if operated according to this manual. For assistance for additional information, consult qualified person, installer or gas supplier.

## 3- DEFINITIONS OF SYMBOLS

The following symbols have been placed at required points in the text in order to draw attention to significant points regarding the usage and assembly of the device. The meanings of the symbols have been specified below.



Indicates that the situation that can only be interfered by qualified person.



Explanations containing information that should be considered by the user.



**CAUTION:** It means that you may suffer from material damage or slight personal injury.

**DANGER:** It means that you may suffer from sever personal injury.

## 4- SAFETY RULES AND WARNINGS

### 4.1. Safety Instructions

#### When a gas leak is found or suspected;

- Turn off the gas valve of the boiler and the valves of all other devices operating with gas.
- Shut off the stove, oven and similar appliances to put their flame out.
- Do not light matches, lighter etc., and stub out your cigarette.
- Ventilate the environment by opening doors and windows.
- Do not ever touch the buttons and plugs of your electrical appliances.
- Turn off the gas valves in the apartment and building entrance.
- Do not use the phones at places where the gas leak is suspected.
- Call your qualified person as soon as possible.
- Do not place and use flammable and explosive liquid or materials around the boiler.
- Keep materials such as water, foam away from electrical connections during operations such as cleaning, gas leak test etc.
- Do not block air vents, openings made in the walls of the room which provide fresh air to the installation room.

### 4.2. Water Systems & Gas Supply Line

- Before installation of the boiler, the water systems (CH & DHW circuit) and gas supply line must be completed in accordance with the relevant regulations and standards by user.

### 4.3. Gas Conversion

- Appliance only work with natural gas. Appliance is not suitable for gas conversion.

### 4.4. Installation

- The boiler must be installed in accordance with national and local requirements, gas safety regulations, relevant standards and this manual by qualified installer.
- The appliance should be mounted against a closed wall.
- The appliance should not be positioned having direct contact to steam, detergent or gases.
- Any change of flue position must not be made without consulting qualified person.
- Sunlight can cause color change on the exterior of your device over time.
- The device must be installed in indoor spaces under normal conditions. However, it can be operated in a suitable cabinet in places such as garage, open balcony. Please consult E.C.A for proper cabinet sizes.
- If device is located in an unheated area, it should be connected to mains, switched on, and pressure of installation should be within operation range so that freeze protection would be activated. Even if device is OFF position, freeze protection stays activated.

### 4.5. Boiler Start Up

- Boiler start up must be performed certainly by qualified person.
- Gas Type (Natural Gas), gas supply pressure (mbar), maximum DHW operating water pressure (bar) and electricity supply voltage on the information plate must be suitable with mains supply conditions. This is checked by qualified person.
- After boiler start up, you should request information about operating the boiler and safety precautions from qualified person.



CAUTION: The 2-amp bipolar fuse with a minimum contact opening of 3 mm must be used in the electrical connection of the boiler.

### 4.6. Usage and Maintenance

Please follow Installation and user operating instructions. This would prevent and misuse and danger that would come from any installation and user error.

- The boiler should be checked and serviced for general maintenance once a year. Maintenance and service operations must be carried out only qualified person.
- Only a damp cloth should be used for cleaning the outer surface of the boiler and then the surfaces should be dried completely. Do not use chemical substances or solutions which cause rust and scratches in your appliances.



**CAUTION:** This device is not intended to be used by persons with physical, sensory or mental disabilities (even children) or persons with inadequate experience and knowledge, unless the person responsible for the safety of the device provides supervision and management of the use of the device. Children must be kept under surveillance to ensure that they do not play with the device. Cleaning and user maintenance should not be done by unattended children.



**CAUTION:** This device is not intended for use by persons (including children) who are low physical or sensory and mental capacity and inexperienced persons without informing and supervising the use of the device by responsible persons. Ensure that children do not play with the appliance.



**CAUTION:** If device is used incorrectly or for other than its intended use, it may present a life hazard and may cause material damage to the product and its surroundings.



**CAUTION:** This device can be used by children over 8 years old and person with physical, sensory or mental disabilities, If proper information regarding safety and use of the device is given and dangers of this appliance is explained.

## 5- PRODUCT

### 5.1. General Specifications

Control panel is ergonomic and easy to use. The Citius Premix condensing combi boiler with elegant plastic control panel and advanced LCD screen provides ease of use and service. On a LCD display with black instrument panel, you can see the operating state icons, heating circuit and operating water adjustment values, the fault / failure codes and the heating water pressure.

With the safety systems available in your device, safety of both you and your device are fully ensured.

These safety systems;

- Flame Failure Safety System
- Boiler Over-Heat Safety System (95 ° C)
- DHW (Domestic Hot Water) Over-Heat System (71 ° C)
- High Water Pressure Protection System (3 bar)
- Low Water Pressure Protection System (0.4 bar)
- Low Voltage Protection System (170 VAC)
- Thermal Accumulation Protection System (with by-pass circuit and "pump over-run")
- Frost Protection System for both CH and DHW circuit)
- Domestic Hot Water Flow Control (only for HM Model)
- Pump Anti-sticking Function
- 3 Way Valve Anti-sticking Function (except HCH Model)
- Automatic Air Vent
- Expansion Vessel (8 liters)
- Maintenance Reminder Function (Yearly)

### 5.2. Notations of Product

Table 1

NOTASYON	AÇIKLAMA
Citius Premix 24/20/14 kW HM	Citius Premix Hermetic Monothermic Condensing Boiler
Citius Premix 24/20/14 kW HCH	Citius Premix Hermetic Central Heating Condensing Boiler
Citius Premix 24/20/14 kW HST	Citius Premix Hermetic Storage Tank Condensing Boiler

### 5.3. Detailed View and List of Components

#### 5.3.1. HM Model

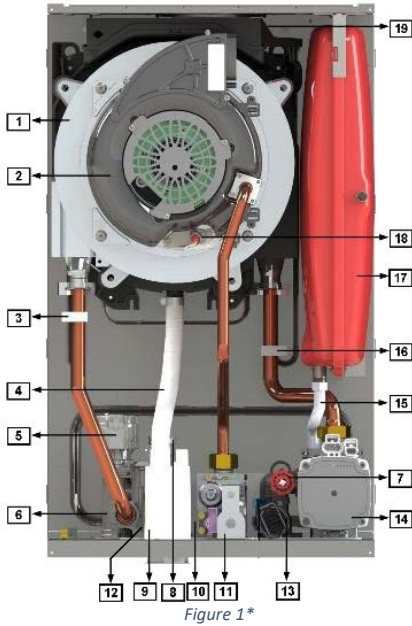

- |     |                                     |
|-----|-------------------------------------|
| 1-  | Main Exchanger                      |
| 2-  | Burner+ Blower System               |
| 3-  | Water Temperature Sensor for Supply |
| 4-  | Condensing Water Hose               |
| 5-  | Motorized Valve                     |
| 6-  | Outlet Manifold                     |
| 7-  | 3 Bar Safety Valve                  |
| 8-  | Pressure Sensor                     |
| 9-  | Siphon                              |
| 10- | Plated Heat Exchanger               |
| 11- | Gas Valve                           |
| 12- | DHW Water Temperature Sensor        |
| 13- | Return Manifold                     |
| 14- | Pump                                |
| 15- | Flexible Connection Hose            |
| 16- | Water Temperature Sensor for Return |
| 17- | Expansion Tank (8 liters)           |
| 18- | Ignition Electrode                  |
| 19- | Flue Gas Sensor                     |

\* Components may be different for some appliance models.

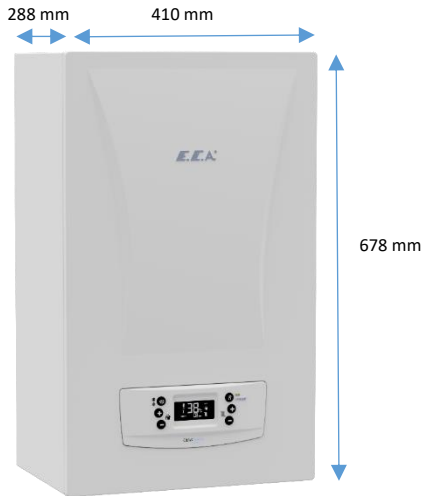

Figure 2 Appliance External Dimensions

### 5.3.2. HST Model

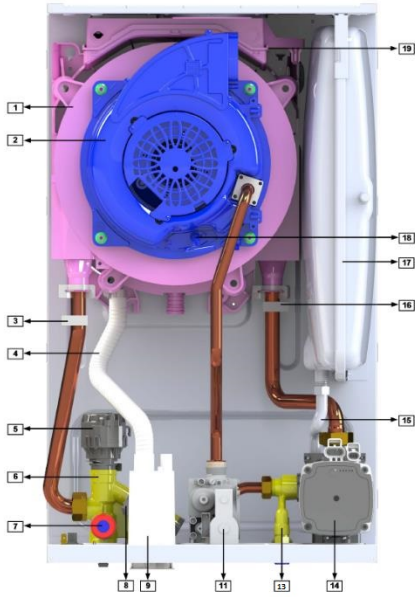

Figure 3

- |     |                                     |
|-----|-------------------------------------|
| 1-  | Main Exchanger                      |
| 2-  | Burner+ Blower System               |
| 3-  | Water Temperature Sensor for Supply |
| 4-  | Condensing Water Hose               |
| 5-  | Motorized Valve                     |
| 6-  | Outlet Manifold                     |
| 7-  | 3 Bar Safety Valve                  |
| 8-  | Pressure Sensor                     |
| 9-  | Siphon                              |
| 10- | Plated Heat Exchanger               |
| 11- | Gas Valve                           |
| 12- | DHW Water Temperature Sensor        |
| 13- | Return Manifold                     |
| 14- | Pump                                |
| 15- | Flexible Connection Hose            |
| 16- | Water Temperature Sensor for Return |
| 17- | Expansion Tank (8 liters)           |
| 18- | Ignition Electrode                  |
| 19- | Flue Gas Sensor                     |

### 5.3.3. HCH Model

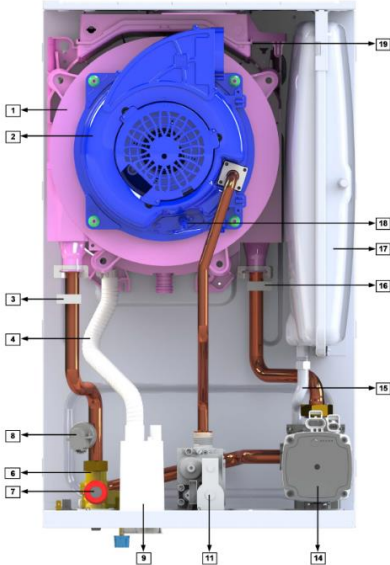

Figure 4

- |     |                                     |
|-----|-------------------------------------|
| 1-  | Main Exchanger                      |
| 2-  | Burner+ Blower System               |
| 3-  | Water Temperature Sensor for Supply |
| 4-  | Condensing Water Hose               |
| 5-  | Motorized Valve                     |
| 6-  | Outlet Manifold                     |
| 7-  | 3 Bar Safety Valve                  |
| 8-  | Pressure Sensor                     |
| 9-  | Siphon                              |
| 10- | Plated Heat Exchanger               |
| 11- | Gas Valve                           |
| 12- | DHW Water Temperature Sensor        |
| 13- | Return Manifold                     |
| 14- | Pump                                |
| 15- | Flexible Connection Hose            |
| 16- | Water Temperature Sensor for Return |
| 17- | Expansion Tank (8 liters)           |
| 18- | Ignition Electrode                  |
| 19- | Flue Gas Sensor                     |

## 5.4. Technical Specifications

Product type	Unit	Citius Premix 24 HM-HCH-HST	Citius Premix 20 HM-HCH-HST	Citius Premix 14 HM-HCH-HST
Gas Category		I2H, I2Esi, I2E(S), I2LL	I2H, I2Esi, I2E(S), I2LL	I2H, I2Esi, I2E(S), I2LL
Flue Types		C13(X), C33(X), C43(X), C53(X), C63(X), C83(X), B23, B33	C13(X), C33(X), C43(X), C53(X), C63(X), C83(X), B23, B33	C13(X), C33(X), C43(X), C53(X), C63(X), C83(X), B23, B33
Gas Input Pressure (G20)	mbar	20	20	20
Gas Input Pressure (G25)	mbar	20/25 mbar	20/25 mbar	20/25 mbar
<b>Capacity-Efficiency</b>				
Min. Heating power - (@60°C min)	kW	5,6	5,6	5,6
Max. Heating power - (@80/60°C) (P4)	kW	24,5	20,2	14,1
Min. Heating power - (@30°C min)	kW	6,7	6,7	6,7
Max. Heating power - (@50/30°C)	kW	26	22,2	15
Min. Heat input (Qn)	kW	6,2	6,2	6,2
Max. Heat input (Qn)	kW	25,2	20,7	14,5
Efficiency (@80°/60° C Max) (Gross Calorific Value)	%	97,50%	97,50%	97,50%
Efficiency (30°C Return) (Gross Calorific Value)	%	107,50%	107,50%	107,50%
<b>ERP Information</b>				
Seasonal Space Heating Energy Efficiency Class		A	A	A
Water Heating Energy Efficiency Class/ Load Profile		A/XL	A/XL	A/XL
Rated Heat Output (Prated)	kW	24,5	20,2	14,1
Seasonal Space Heating Energy Efficiency	%	92,16	92	92
Water Heating Energy Efficiency	%	85	85	85
Sound Power Level	dB(A)	52	52	52
Efficiency at Rated Heat Output At High Temperature Regime (η4)	%	87,9	87,9	87,9
Efficiency at 30% of rated Output At Low Temperature Regime (η1)	%	97,0	97,0	97,0
At Full Load elmax	kW	0,044	0,034	0,025
At Part Load elmin	kW	0,016	0,016	0,016
In standby Mode	kW	0,003	0,002	0,002
Standby Heat Loss	kW	0,065	0,065	0,065
Emissions of Nox Level	mg/kWh	44	40	36
Daily Electricity Consumption (Qelect)	kWh	0,2	0,2	0,2
Daily Fuel Consumption (Qfuel)	kWh	22,4	22,4	22,4
<b>Gas Consumption</b>				
Natural Gas (@Min-Max Capacity)	m <sup>3</sup> /h	0,65-2,65	0,65 - 2,2	0,65 - 1,53
NOx Class		6	6	6
<b>Central Heating</b>				
Min. Water Pressure	bar	0,4	0,4	0,4
Max. Water Pressure	bar	3	3	3
Operation Range (@Radiator heating)	°C	30-80	30-80	30-80
Operation Range (@Underfloor heating)	°C	30-45	30-45	30-45
Max. Limit temperature	°C	> 95	> 95	> 95
<b>Domestic Hot Water (only valid for HM)</b>				
Min. Domestic flow for operating	L/min.	2 (±10)	2 (±10)	2 (±10)
Min. Domestic flow for closing	L/min.	1,5 (±10)	1,5 (±10)	1,5 (±10)
Max. Domestic hot water flow rate	L/min.	10 ±%15 (ΔT = 34,7°C)	10 ±%15 (ΔT = 34,7°C)	10 ±%15 (ΔT = 34,7°C)
Min. Water Pressure	bar	0,4	0,4	0,4
Max. Water Pressure	bar	10	10	10
Operation Range	°C	30-65	30-65	30-65
Max. Limit temperature	°C	≥ 71	≥ 71	≥ 71
<b>General</b>				
Electrical Supply	V AC-Hz	230 VAC-50 Hz	230 VAC-50 Hz	230 VAC-50 Hz
Electrical consumption (Max-Std Pump)	Watt	165	150	130
Electrical consumption (Max-HE Pump)	Watt	120	120	120
Protection Class		IPX4D	IPX4D	IPX4D
Expansion Vessel	lt	8	8	8
Weight (Net)	kg	29	29	29
Dimensions (HxWxD)	mm	678*410*288	678*410*288	678*410*288



<b>Flue Lengths</b>				
C13 – 60/100 Max.	m	10	10	10
C13 – 80/125 Max.	m	20	20	20
C33 – 60/100 Max.	m	10	10	10
C33 – 80/125 Max.	m	20	20	20
C43 – 60/100 Max.	m	10	10	10
C53 – 60/100 Max.	m	10	10	10
C83 – 80/80 Max.	m	28	28	28
C83 – 80/80 Min.	m	3	3	3
B23 – 80 Max.	m	28	28	28
B23 – 80 Min.	m	3	3	3
B33- 60/100 Max.	m	10	10	10
<b>Emission Values</b>				
CO <sub>2</sub> ratio (@max-G20)	%	9,0 ± 0,2	9,0 ± 0,2	9,0 ± 0,2
CO <sub>2</sub> ratio (@min-G20)	%	8,4 ± 0,2	8,4 ± 0,2	8,4 ± 0,2
<b>Boiler Circuit (only valid for HST)</b>				
Operation Range	°C	30-65	30-65	30-65
Max. Limit temperature	°C	≥ 85	≥ 85	≥ 85

Table 2

## 5.5. Electrical Drawing

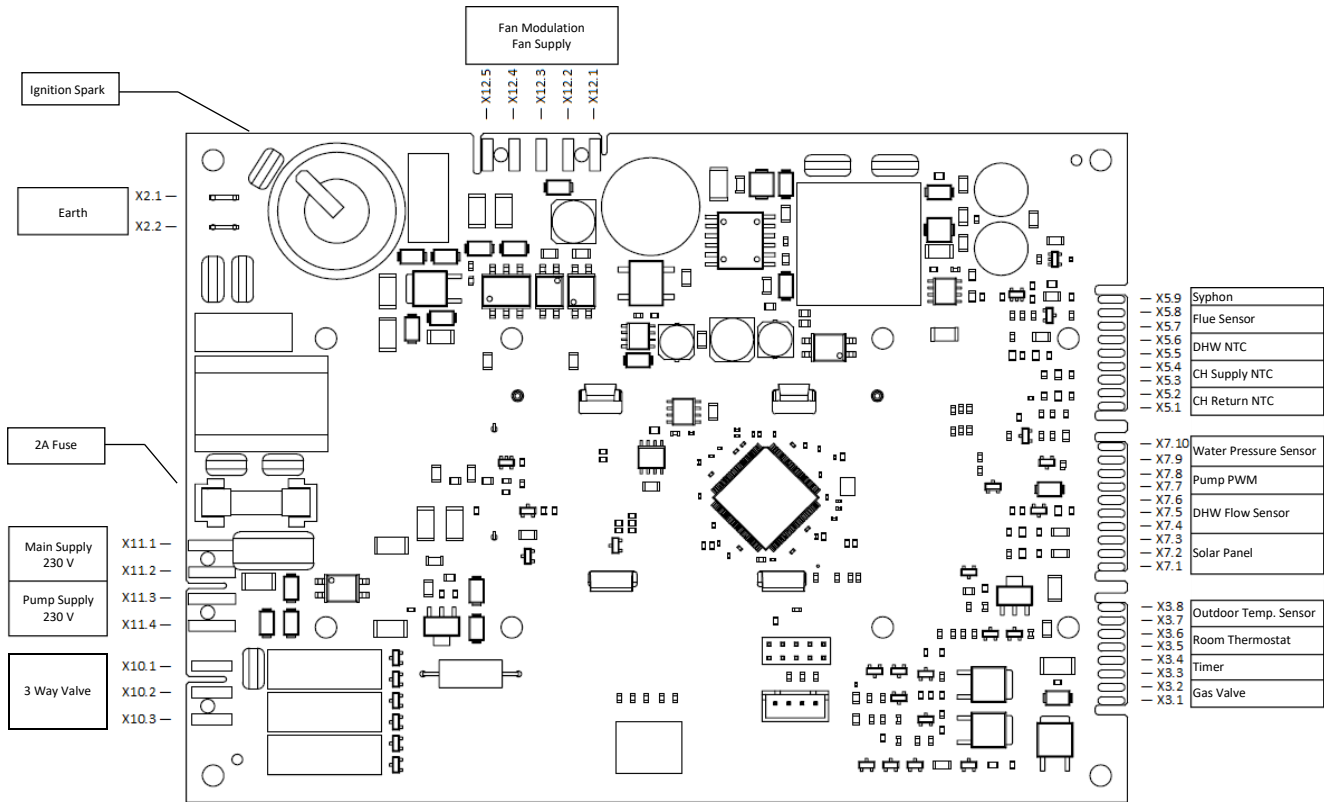

Figure 5

## 6- BOILER PACKAGING



**CAUTION:** Attention must be paid to warning on packaging regarding handling and storage.

- The device is delivered with a carton board with dimensions of 735 x 345 x 490 (HxWxD) mm, supported by upper and lower styrofoam.

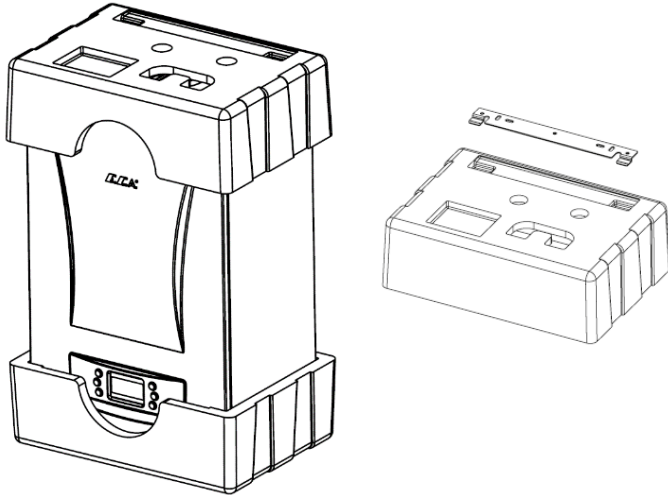

Figure 6

- Parts required for installation of the device (wall bracket, 5 gaskets for HM and HCH and 6 gaskets for HST water and gas connections, 3 anchors and 3 fixing screws) are placed on the top styrofoam.
- The hermetic flue set is delivered in a carton box separate from the unit. The standard hermetic flue set ( $\varnothing$  60/100 or  $\varnothing$  80/125) consists of the following components (Figure 7).

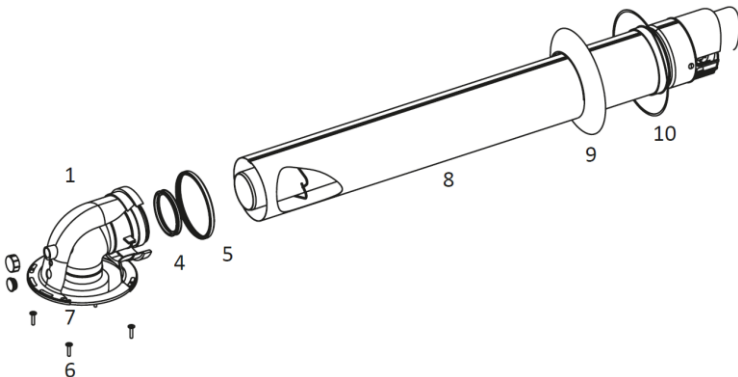

Figure 7

1-	90° Elbow	6-	Flange Screws
2-	Exhaust Gas Tap	7-	Flange Gaskets
3-	Air Inlet Tap	8-	Flue Exhaust Terminal
4-	Sealing Gasket $\varnothing 60$ or $\varnothing 80$	9-	Inner Wall Connection Flange
5-	Sealing Gasket $\varnothing 100$ or $\varnothing 125$	10-	Outer Wall Connection Flange (EPDM)

Table 3

## 7- FLUES

### 7.1. Flue Sizes

Flue gas connections between the boiler and the flue terminal must be made using original components specially designed for the condensing boiler to ensure that the device operates efficiently and correctly.

Flue gas pipes and fittings of non-condensing boilers cannot be used for exhausting gases from condensing boilers. In the horizontal concentric flues, the exhaust gas pipe (the inner pipe) facing outwards should be inclined upward and the fresh air pipe (outer pipe) should be inclined downward. When the original flue set is installed parallel to the ground, the exhaust gas pipe is automatically inclined upwards.

Equivalent length for each 90° elbow: 1 m

Equivalent length for each 45° elbow: 0.5 m

### 7.2. Flue Types

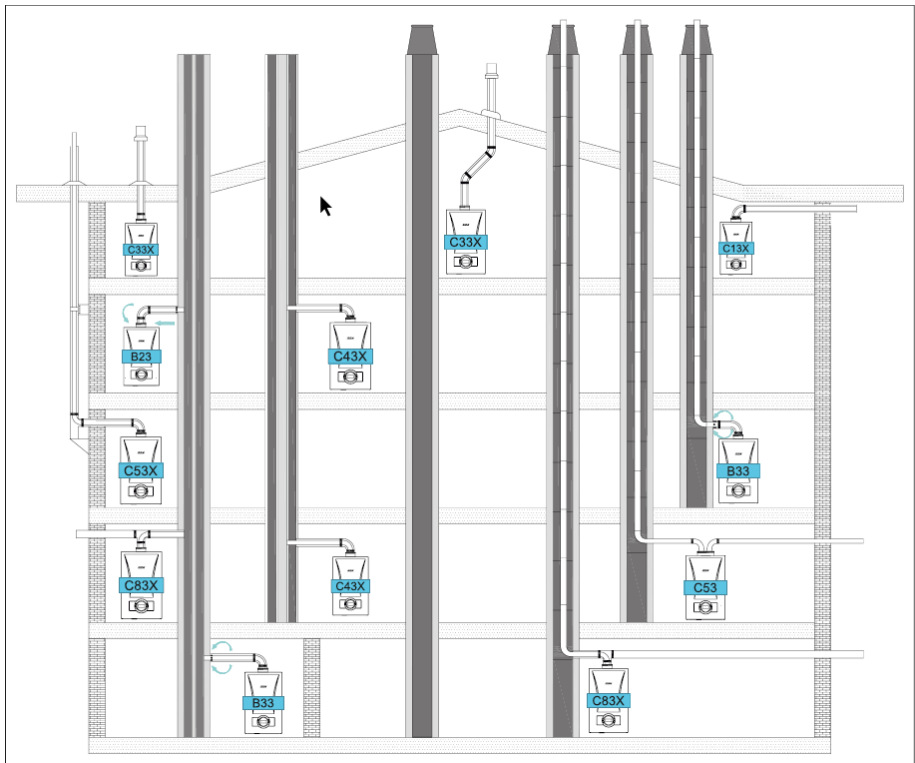

Figure 8

### 7.3 Distances for Placement of Flues

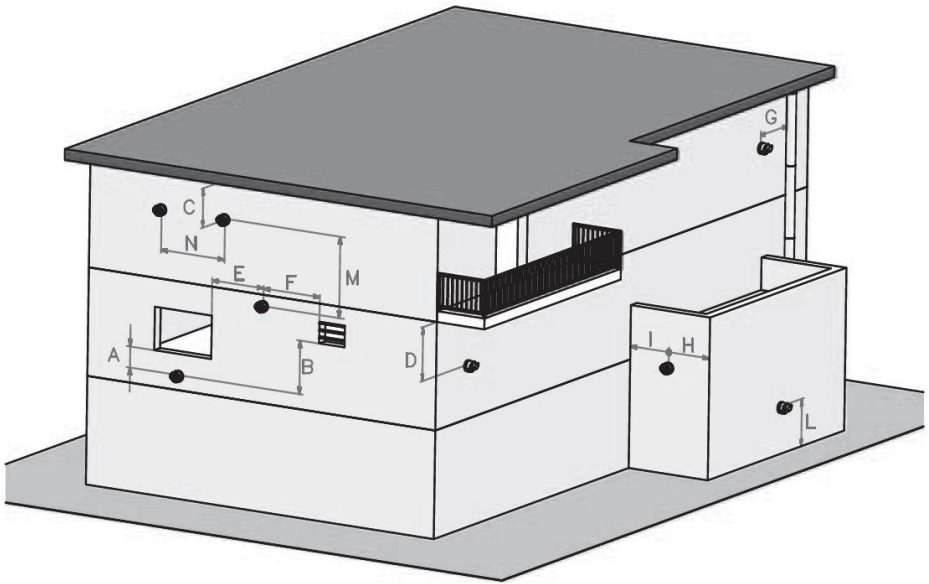

Figure 9

POSITION	DISTANCE (cm)	POSITION	DISTANCE (cm)
A- Below a windows	60	G- Next to vertical or horizontal pipe	60
B- Below an air vent	60	H- Below the distance grille from the outside of the building	30
C- Below rain channel	30	I- Distance from the inner corner of the building	100
D- Under the balcony	30	L- From the ground or from the floor	180
E- Next to a window	40	M- Vertical distance of two flue outlets	150
F- Next to an air grill	60	N- Horizontal distance of two flue outlets	100

Table 4

## 8- INSTALLATION

### 8.1 Selection of Installation Location of Device

The boiler must be installed in accordance with gas safety regulations and relevant standards. Additionally, the clearance around the boiler should be as shown in figure 10. In order to make service, maintenance and usage easier.

Figure 9: It shows the minimum distances required from the top and sides of the device (Dimensions given in mm).

The installation must comply with the following minimum distances so that servicing and maintenance of the boiler can be performed correctly. The position of the boiler must be checked against technical requirements.

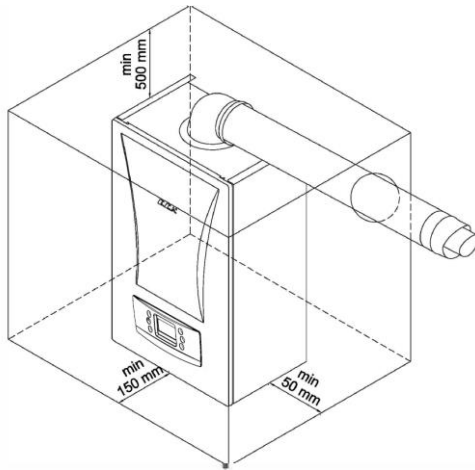

Figure 10



- The device can be used at altitudes up to 2000 m above sea level.



- There is no need to remove side panels in the combi boiler service operations. Minimum 50 mm clearances are given taking into consideration the share of possible side panel sheet changes.



- Do not install your boilers in locations that will be exposed to direct sunlight. Sunlight can cause color change on the exterior of your device over time.
- Ambient temperature of device's installation location should be between 5-35°C.

Since the outside temperature of the device does not rise above 85 ° C at the maximum heating power, no special protective measures are required against the combustible construction materials and components.

## 8.2. Independent Operation from Ambient Air (Type C)



**DANGER:** For room sealed operation, the boiler location and air/flue terminal position must obey national and local requirements, gas safety regulations and relevant standards.

Type C (hermetic) devices are not suitable for outdoor installations. These devices should be installed inside the building.

In case of gas leakage, it is necessary to vent the installation room according to national and local requirements, although the room sealed operation boilers are independent of room volume and ventilation.



**DANGER:** Do not block the air vents which provide fresh air to the installation room.

The air/flue terminal must be exposed to the external air and allow free passage of air cross it at all times.

- The minimum acceptable dimensions from the terminal to obstructions an ventilation openings must obey national and local requirements.
- All horizontally fitted ducts (air/flue) should be fitted 2° or 3° upwards incline to allow condensate water drain to the boiler.



- The flue ducts are always wet.



- Under cold or excessive humid weather conditions the water vapor inside the waste gas may condensate while leaving the flue.

## 8.3. Mounting the Boiler

Having determined the boiler location;

- The points of lock screws of wall bracket and assembly bracket are marked by using the assembly template inside installation and user's operating instructions of the device (pages 34-35-36). The mounting bracket is an optional part.
- After drilling the marked points, wall assembly bracket and assembly bracket are fixed on the wall by the dowel and lock screws which are inside the packaging of the device.
- Finally, the boiler is hanged on the wall by placing the assembly bracket on the back side of the boiler on the mounting bracket assembled on the wall.

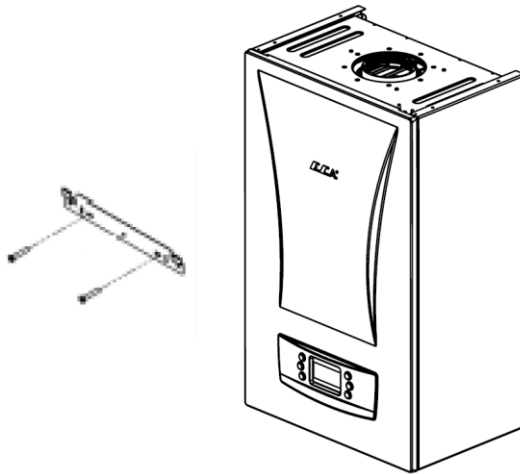

Figure 11

## 9- CONNECTIONS

### 9.1. Condensate Discharge Connection



All condensing boilers generate condensing discharge. The amount of the condensate water depends on the working conditions of your appliance. This can be up to 1.7 liters condensate water an hour.

- The condensation water must be connected to a drain with the help of a plastic hose that is connected to the end of siphon. The use of standard discharge hose is recommended for connection to the drain. The addition of one cable connection on the hose should be made for fixing.
- If drain hose will be connected to drain outside of the building, insulation should be provided to prevent freeze of hose.
- The condensate discharge hose and interconnection parts must be made of plastic material.
- All horizontal parts must be connected at a slight 2° or 3° downwards incline to ensure to a good flow.



Figure 12



## 9.2. Gas and Water Connections

### 9.2.1. HM Model

- Water and gas supply connections between the boiler and the mounting bracket can be fixed with the optional pipes and the nipples as shown in Figure 12.

- a) CH flow  $\frac{3}{4}$ " (hot)
- b) DHW outlet  $\frac{1}{2}$ " (hot)
- c) Gas inlet  $\frac{3}{8}$ "
- d) DHW inlet  $\frac{1}{2}$ " (cold)
- e) CH return  $\frac{3}{4}$ " (cold)

- A suitable valve should be mounted on the gas inlet and CH & DHW water circuit. In addition, a water filter should be mounted on CH (3/4") return and DHW (1/2") inlet.
- A plastic pipe should be fixed the outlet tap of the three bar relief valve and the pipe should be connected to the drain line.
- The connection between the appliance and gas supply must be made with a flexible pipe.

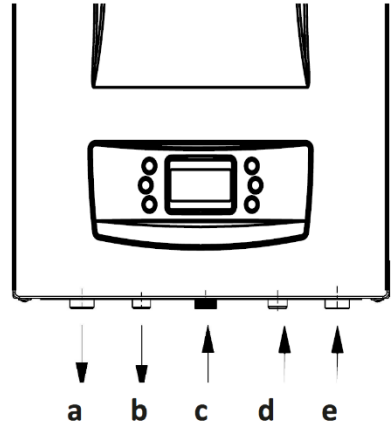

Figure 13

### 9.2.2. HCH Model

- a) CH flow  $\frac{3}{4}$ " (hot)
- b) Water filling line 1/2"
- c) Gas inlet  $\frac{3}{8}$ "
- d) CH return  $\frac{3}{4}$ " (cold)

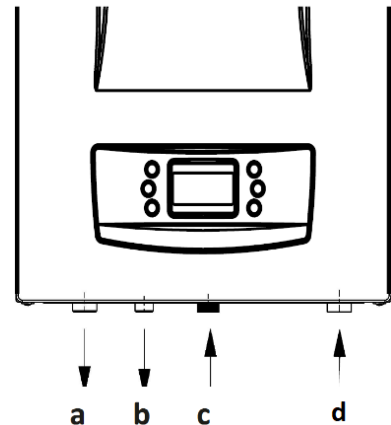

Figure 14

### 9.2.3. HST Model

- a) CH flow ¾" (hot)
- b) Boiler supply water (hot)
- c) Gas inlet ¾"
- d) Boiler return (cold)
- e) Installation Filling Line ½"
- f) CH return ¾" (cold)

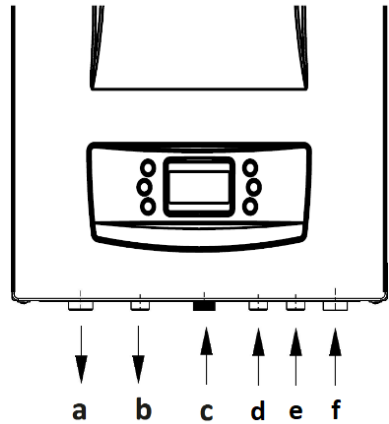

Figure 15

### 9.3. Electrical Connection

Electrical installation should be made according to the national and local instructions. The boiler must be earthed and a standard 230 V AC – 50 Hz supply is required.



**CAUTION:** Disconnect power supply to prevent electrical shock before connecting the electrical supply.



**CAUTION:** If the supply cord is damaged, it must be replaced by the manufacture, its service agent or similarly qualified person in order to avoid a hazard.



**CAUTION:** The 2-amp bipolar fuse with a minimum contact opening of 3 mm must be used in the electrical connection of the boiler.



**CAUTION:** The cable diameter (including insulation) of the electrical installation to be installed must be at least 14 mm and the pipe diameter used must be at least 16 mm.

**9.4. Room Thermostat**

Optional room thermostats compatible with your device can be used to control heating system.



E.C.A. On/Off Room Thermostat  
T6360  
7006901312



E.C.A. Digital Room Modulated  
Programmable LAGO FB OT  
7006902518



E.C.A. Smart Room  
Thermostat  
7006907531



E.C.A. Digital Room Thermostat  
Programmable CM727  
7006902046



E.C.A. Digital Room Thermostat  
Honeywell DT90  
7006902502



E.C.A. On/Off No Wire Room  
Thermostat  
7006907522

E.C.A. On/Off No Wire Room  
Thermostat  
7006907519



E.C.A. Programmable Digital Room  
Thermostat- CM707  
7006901313  
No Wire  
7006901501

Figure 16

## 9.5. Outdoor Sensor

To connect the room thermostat or outdoor sensor to the device, the connections behind the control panel are used. For the room thermostat, the bridged cable connection on the back of the control panel is removed and the outer air sensor is connected to free sockets on the terminal.



- It can be provided as an option according to boiler models.
- It allows operation of combi boiler adjusted to outside temperature.

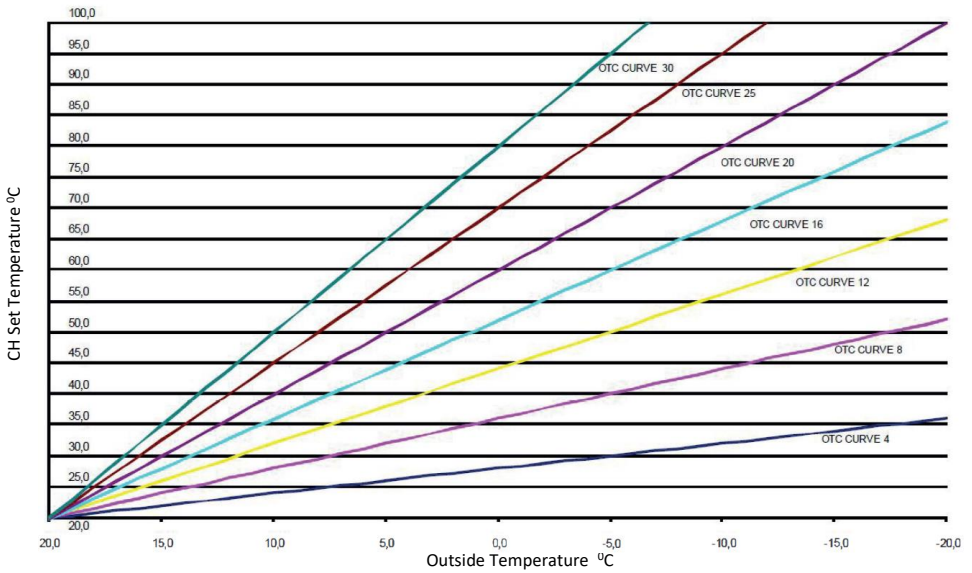

Figure 17

9.6. Room Thermostat and Outer Air Sensor Connection

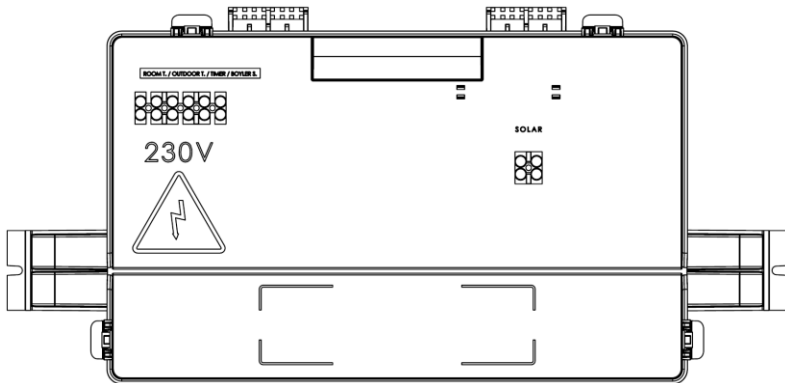
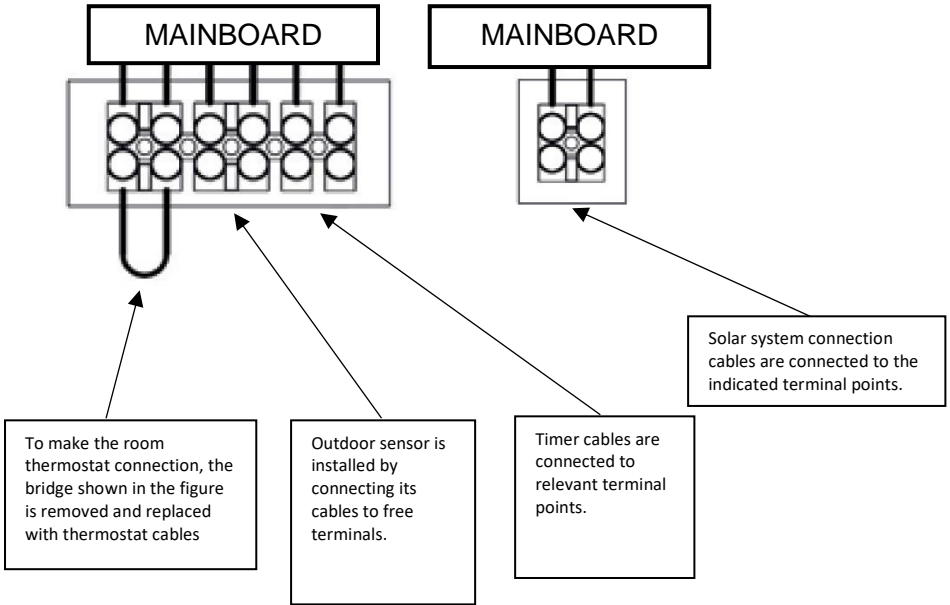

Figure 18

- Cancel the bridge on the other side on room thermostat connection.
- Only the room thermostats deemed to be appropriate by authorized services of E.C.A. should be used on your boiler. Otherwise, it may cause the malfunction of your device. Responsibility is not undertaken under such conditions.



The connections of room thermostat, outdoor sensor and timer must be performed certainly by qualified person.

## 10- COMMISSIONING, USE AND TURNING OFF THE BOILER

### 10.1. Commissioning, Filling Water into Boiler and Heater Installation

- First of all, the electrical connection of the boiler is done. The electrical connection of the device must be connected to a grounded power supply line that can supply enough voltage (230 VAC, 50 Hz) for the device.
- All radiator valves should be opened.
- CH flow and CH return of boiler should be opened. Check them.
- After all these processes, filling valve is slowly opened and filling procedure is initiated. The filling process continues until the water pressure of 1.5-2 bar is seen on the LCD display and then the filling valve is closed.
- When the water pressure increase to 0.8 bar, the LCD will show "AP" and the boiler will switch to automatic air vent mode. In this case you should definitely wait for 160 seconds without pressing "RESET".
- Check water pressure on pressure indicator frequently and ensure that the pressure is between 1.5 and 2 bar when system is cold. If the pressure drops frequently, it means that there is a water leak in the system. In such case, it is necessary to call a plumber.

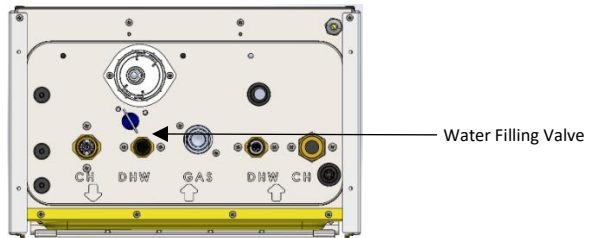

Figure 19



**ATTENTION :** Always close the water filling valve, the installation water may leak and damage the environment.

- To discharge air out of CH installation, purgers of the radiator is loosened and air is discharged until water comes out of radiators. This procedure is done for all radiators.
- Pressure is checked again on LCD screen. The filling valve is opened and again pressure is raised to 1.5 – 2 bar level.
- Radiator purgers are checked again to see if there is any air left inside of heating installation. For full efficient heating, all air must be discharged.
- Finally, check for any leaks in the radiator and piping.



**ATTENTION:** In order to prevent calcification of the heat exchanger, you are advised not to use well water, natural spring water instead of mains water.

- Check the domestic water installation by opening the hot water tap. Check for any leaks in the piping.
- The exhaust gas flue assembly must be installed from the original parts in accordance with the instructions.
- Gas supply must be checked by the qualified gas company.
- Must be called authorized service to start up the boiler after all these processes are completed.
- Commissioning must be strictly performed by authorized service.
- At the end of the commissioning of the device after installation, please ask for information of authorized service on operating the device and relevant safety devices on device.

## 10.2. Using the Device

### 10.2.1. Switching off the Device

You can switch off the boiler by holding down the ON/ OFF button for 3 seconds.

LCD light will be OFF after 1 minute.

Anti-freeze function remains active.

## 11- CONTROL PANEL

### 11.1. Functions of Buttons

The control panel consists of the relevant elements as shown in figure below.



Figure 20

#### 1 Position Selection Button

The position can be changed by pressing the position selection button once to change between the winter mode and the summer mode. If the button is pressed for 3 seconds, the device will switch into "standby" position. It will suffice to press the button once to get the device in operation position.

#### 2 Reset Button

Main functions:

- Exit from lockout error (EXX)
- ECO mode activation
- Comfort mode activation

When your device fails, the error code will start flashing on the display. There are 2 types of errors, lockout (EXX) and blocking (FXX) error. When a lockout error condition occurs (EXX), the error must first be corrected so that the error code can be removed from the LCD screen. After pressing the "Reset" key once, the device can switch back to normal operation state. As for a blocking error, the fault cannot be removed from the LCD display pressing the "Reset" button (FXX). When this error is corrected, error code is automatically disappears from LCD screen.

The first time the device starts, it will start working in Comfort mode.

Once the Reset button is pressed when operating in Comfort mode, the device will switch to Eco mode. Then when Reset button is pressed again, the unit will switch to Comfort mode.

### 3 Domestic Hot Water Increase Temperature Button

The temperature of the domestic water can be increased up to 65 °C thanks to the domestic water temperature increase button.

### 4 Central Heating Water Increase Temperature Button

The temperature of the heating water can be increased up to 80 °C thanks to the heating water temperature increase button.

### 5 Domestic Hot Water Decrease Temperature Button

The temperature of the domestic water can be decreased down to 30 °C thanks to the domestic water temperature decrease button.

### 6 Central Heating Water Decrease Temperature Button

The temperature of the heating water can be decreased down to 30 °C thanks to the heating water temperature decrease button.

## 11.2. LCD Screen

LCD screen display icons described here below.

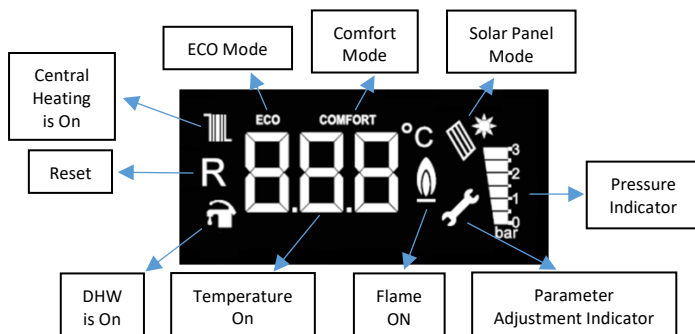

Figure 21

#### 11.2.1. Flame Icon

When operating between 0% and 50% capacity range, the icon is displayed on the LCD screen as single bar, whereas it is displayed as two bars when operating between 50% -100% capacity range.

#### 11.2.2. Pressure Indicator

The LCD display shows 0-0,5-1-1,5-2-2,5-3 bar water pressure values. The values other than these ones are not displayed. Only when filling after C37 (Low water pressure error) fault, the pressure value is displayed in the temperature value section.

## 11.3. Operation Functions

### 11.3.1. Standby (OFF Mode)

The mode where device can be set to standby mode. In this mode, no requests for heating water and domestic water can be made. To activate the OFF mode, it is necessary to keep button no. 1 (position selector) pressed for 3 seconds continuously. When -OFF- is displayed on screen, mode is activated.



### 11.3.2. Air Discharge Mode (AP Mode)

It is the process that the device automatically activates to discharge air in the central heating installation for 160 seconds. In this mode, "AP" is displayed on the screen.

The circulation pump runs for 15 seconds then stops every 5 seconds in intervals of every 20 seconds. The three-way valve motor also changes position between a CH-DHW in 40 seconds. The situations where this mode is activated is listed here below.

- Once the device is powered for the first time or after the electricity has been switched off and on,
- After the reset operation following the overheating fault (A03),
- After elimination of high water pressure (C40) or low water pressure (C37) error,



Do not press 'RESET' while AP mode is active.

### 11.3.3. Winter Mode – Radiator Heating

If the device in the standby position is set to the winter position, the appliance will heat the water in the heating circuit until the domestic water is needed. In the winter mode, both the tap and the radiator icon are displayed on the LCD screen. When a request for heating is made for radiator, radiator icon flashes (once/second), tap icon stays fixed. When a request for domestic water is made, tap icon flashes (once/second), radiator icon stays fixed. In this mode, radiator heating circuit's temperature can be set between 30-80°C. For under floor heating applications, the temperature range can be set between 30-45°C.

### 11.3.4. Summer Mode

If the device in the OFF position is set to the summer position, the device will only respond to the domestic hot water demands. In summer mode, the tap symbol appears fixed on the LCD screen, the radiator icon does not appear. When the domestic hot water is heating request, the tap symbol flashes (1 time / second). In this mode, the domestic hot water temperature can be adjusted between 30-65°C.

### 11.3.5. Comfort Mode

The standard operating mode of the device is Comfort mode. By pressing the "Reset" button, Eco-Comfort modes can be switched. When Comfort mode is active, "Comfort" icon is displayed on the LCD screen. Comfort mode is only for radiator heating circuit. It has no effect on use of domestic water circuit. In this mode, the device responds to fast heating demands by running in modulation.

### 11.3.6. ECO Mode

By pressing the "Reset" button, Eco-Comfort modes can be switched. When Eco mode is active, "Eco" icon is displayed on the LCD screen. Eco mode is only for radiator heating circuit. It has no effect on use of domestic water circuit. This mode allows savings on fuel by performing on-off operation.



### 11.3.7. Maintenance Reminder Mode

It is the mode where a reminder for yearly maintenance is activated. When this mode is active, only "ASE" is displayed on screen and device continues to meet heating requests. When you see "ASE" on screen, please get in contact with E.C.A authorized services for yearly maintenance.

### 11.3.8. Anti-Frost Mode

During the winter season, when the installation water temperature falls below 6°C, the anti-freeze function is activated and the device continues to operate until the water output of installation rises to 15°C. In order for anti-freeze function to be activated, the following conditions must be checked and ensured by the customer.

- The power supply of the device must be switched on.
- The gas valve and radiator valves must be open.
- Water pressure of system should be at appropriate level.
- The anti-freeze function helps protect your device, it does not protect your installation.
- If device will not be operated for a while in places where there is risk of freezing, then it is necessary to drain the water or to use an anti-freeze agent.

## 12- ERROR CODES AND DESCRIPTIONS

Error Code	Error Type	Possible Cause	Troubleshooting
A00	<b>The Electronic Card Software Fault</b>	The electronic card software may Be failed.	1- Press reset button. 2- If the error is still present (or persists) after reset, notify authorized service of E.C.A.
A01	<b>Ignition Fault</b>	No gas connection for boiler.	1- Check that the gas valve is open. 2-Check if there is gas in installation. 3- Press reset button. 4- If the error is still present (or persists) after reset, notify authorized service of E.C.A.
A02	<b>False flame indication</b>	It is triggered if flame is detected in the burner while gas valve is closed.	1- Press reset button. 2- If the error is still present (or persists) after reset, notify authorized service of E.C.A.
A03	<b>High limit temperature protection</b>	It will occur if the temperature of ingoing and outgoing water exceeds 90° C.	1- Check that water valves of boiler installation are open. 2- If the boiler triggers this error in winter mode, check that at least 1 radiator is open. 3- Press reset button. 4- If the error is still present (or persists) after reset, notify authorized service of E.C.A.
A05	<b>No frequency feedback from fan after 1 minute</b>	Failure of fan or fan cable	1- Press reset button. 2- If the error is still present (or persists) after reset, notify authorized service of E.C.A.
A06	<b>Required fan speed can't be reached</b>	Failure of fan or fan cable	1- Press reset button. 2- If the error is still present (or persists) after reset, notify authorized service of E.C.A.
A08	<b>Flame circuit failure</b>	The electronic card may be failed.	1- Press reset button. 2- If the error is still present (or persists) after reset, notify authorized service of E.C.A.  1- Replace electronic board. 2- Check cables of ignition electrode. 3- Check ignition electrode.
A09	<b>Valve feedback error</b>	The gas valve may be failed.	1- Press reset button. 2- If the error is still present (or persists) after reset, notify authorized service of E.C.A.
A12	<b>EEPROM check fail</b>	The electronic card may be failed.	1- Press reset button. 2- If the error is still present (or persists) after reset, notify authorized service of E.C.A.
A15	<b>Measurement deviation fault of temperature sensors</b>	Temperature sensors might be defective.	1- Press reset button. 2- If the error is still present (or persists) after reset, notify authorized service of E.C.A.

<b>A16</b>	<b>Error on Temperature Sensor for Outgoing Water</b>	No temperature is detected by temperature sensor for outgoing water.	1- Press reset button. 2- If the error is still present (or persists) after reset, notify authorized service of E.C.A.
<b>A17</b>	<b>Error on Temperature Sensor for Returning Water</b>	No temperature is detected by temperature sensor for returning water.	1- Press reset button. 2- If the error is still present (or persists) after reset, notify authorized service of E.C.A.
<b>A18</b>	<b>Temperature Sensor Error</b>	The temperature change on the temperature sensor is too high (> 30 °C)	1- Press reset button. 2- If the error is still present (or persists) after reset, notify authorized service of E.C.A.
<b>A21</b>	<b>Analog to digital converter failure</b>	The electronic card may be failed.	1- Press reset button. 2- If the error is still present (or persists) after reset, notify authorized service of E.C.A.
<b>A33</b>	<b>Error on Temperature Sensor for Returning Water</b>	The return water temperature sensor is in short or open circuit state.	1- Press reset button. 2- If the error is still present (or persists) after reset, notify authorized service of E.C.A.
<b>A35</b>	<b>Error on Temperature Sensor for Outgoing Water</b>	The outgoing water temperature sensor is in short or open circuit state.	1- Press reset button. 2- If the error is still present (or persists) after reset, notify authorized service of E.C.A.
<b>A80</b>	<b>Temperature difference error between ingoing water temperature and outgoing water temperature sensor</b>	Temperature detected by temperature sensor for ingoing water is higher than temperature detected by temperature sensor for outgoing sensor	1- Press reset button. 2- If the error is still present (or persists) after reset, notify authorized service of E.C.A.
<b>A82</b>	<b>Flame failure (more than 3 flame failures in 4 minutes)</b>	Flame detection problem	1- Press reset button. 2- If the error is still present (or persists) after reset, notify authorized service of E.C.A.
<b>C07</b>	<b>Over Temperature Error for Flue Gas</b>	It occurs when the temperature of the flue gas exceeds 95 °C.	Notify authorized service of E.C.A.
<b>C13</b>	<b>Repeated Reset Failure</b>	Pressing of Reset button more than 5 times in an hour	Notify authorized service of E.C.A.
<b>C25</b>	<b>Electronic Card Failure</b>	The electronic card may be failed.	Notify authorized service of E.C.A.
<b>C34</b>	<b>Low Supply Voltage</b>	It occurs when the supply voltage falls below 170V.	Notify authorized service of E.C.A.
<b>C37</b>	<b>Low Water Pressure Fault</b>	It occurs when water pressure sensor detects a relatively low water pressure (0.4 bar) for your device.	1- Check water pressure in heater installation of your device. 2- Fill the system with water until the pressure reaches 1.5-2 bar (device will eliminate error when the pressure is over 0,8 bar). 3-Check your valves and installation against leaks. 4- If the problem is still present (or persists), notify authorized service of E.C.A.

<b>C39</b>	<b>Outer Air Sensor Fault</b>	Outer air sensor might be defective.	1- Press reset button. 2- If the error is still present (or persists) after reset, notify authorized service of E.C.A.
<b>C40</b>	<b>High Water Pressure Fault</b>	It occurs when water pressure sensor detects a relatively high water pressure (3,3 ±0,3 bar) for your device.	1- Check water pressure in heater installation of your device. 2- Tur off the device and restart it. 3- If the error is still present (or persists) after reset, notify authorized service of E.C.A.
<b>C47</b>	<b>Water Pressure Sensor Error</b>	Water pressure sensor is not plugged in or there is no contact.	1- Press reset button. 2- If the error is still present (or persists) after reset, notify authorized service of E.C.A.
<b>C50</b>	<b>Boiler Sensor Fault</b>	Boiler sensor might be defective.	1- Press reset button. 2- If the error is still present (or persists) after reset, notify authorized service of E.C.A.
<b>C51</b>	<b>PT1000 Solar Sensor Error</b>	PT1000 solar sensor might be defective.	1- Press reset button. 2- If the error is still present (or persists) after reset, notify authorized service of E.C.A.
<b>C52</b>	<b>Error on temperature sensor for domestic water</b>	Temperature sensor for domestic water might be defective.	Notify authorized service of E.C.A.
<b>C53</b>	<b>Error on temperature sensor for flue gas</b>	The flue gas temperature sensor is in short or open circuit state.	Notify authorized service of E.C.A.
<b>C81</b>	<b>Temperature sensor deviation test delay</b>	Temperature sensors might be defective.	Notify authorized service of E.C.A.

Table 5

## **13- USEFULL INFORMATION ON PRODUCT**

### **13.1. Information on the Efficient Use of the Combi Boiler in Terms of Safety and Energy Consumption**

Isolation of your building is extremely important. Energy saving is achieved at a considerable degree since the heat loss is lowest in houses with double-glazed windows and insulated walls.

- The use of thermostatic valves in your radiators ensures that the room temperature is constant or allows you to save money.
- Turning radiator valves lower levels in the rooms which will not be used for a long time and keeping the doors closed keeps fuel consumption low.
- If you use the program clock with your device, the combi boiler operates at the times you set and consumes less fuel.
- Covering the radiator top and sides with furniture-like things negatively affects hot air circulation, thus prevents the environment from overheating and increases fuel consumption.
- If you will leave your device in operation late at night, keeping water temperature of the heating circuit at low levels will ensure saving.
- If you feel that the room temperature is high, the radiator valves should be closed instead of opening windows.

### **13.2. Clogging in Installation**

- In old installations with iron pipes, usually clogging occurs short time after the device is commissioned.
- If clogging in installation is encountered with, then inhibitor (Sentinel X400, etc.) should be added to installation water.

### **13.3. Cleaning of Boiler**

Keep the outer casing of the combi boiler clean by wiping it with a soft dampened cloth. Do not use strong, abrasive cleaning agents.

Performing the maintenance once a year during the warranty period and periodically before the winter season after the warranty expires ensures safe use, saves fuel and extends the useful life of the boiler.

Make sure periodic maintenance is strictly performed by E.C.A. Authorized Services.

Use original spare parts only to ensure maximum life span and safety of the device.

E.C.A will not be responsible for damages to device or material or living beings nearby caused by maintenance performed by unauthorized service or staff.

### **13.4. Extending Guarantee Period and Guarantee Stars**

#### **13.4.1. Extended Warranty**

You can extend the guarantee period of your device from 1 year to 3 years by taking advantage of the "Plus Warranty" service within 4 months from the date of the commissioning of your boiler. In the event of a failure during additional warranty period (Plus 1, 2, 3 year(s)) you will not be charged for labor, spare parts and travel costs.

Once in a year during contract period, general maintenance of your boiler can be performed free of charge by an authorized service of E.C.A.

#### **13.4.2. Guarantee Stars**

You can get warranty of 1 to 3 years for your safely used E.C.A boilers, of which guarantee period expires. Thanks to guarantee stars and through additional warranty, your device with expired guarantee can be provided with maintenance up to 3 years without charging for spare parts, labor and service charges.

General maintenance service is offered free of charge once in every year.

You can contact Call Center dialing 444 0 322 for 24 hours in a day and your application will be answered within 3 hours, and your boiler will be serviced.

**Note:** The said guarantee is valid for maximum 10 year old combi boilers in cities where natural gas is used.

14- ANNEXES

14.1. Characteristic curve of water pressure height of the pump (pump head-flow rate)

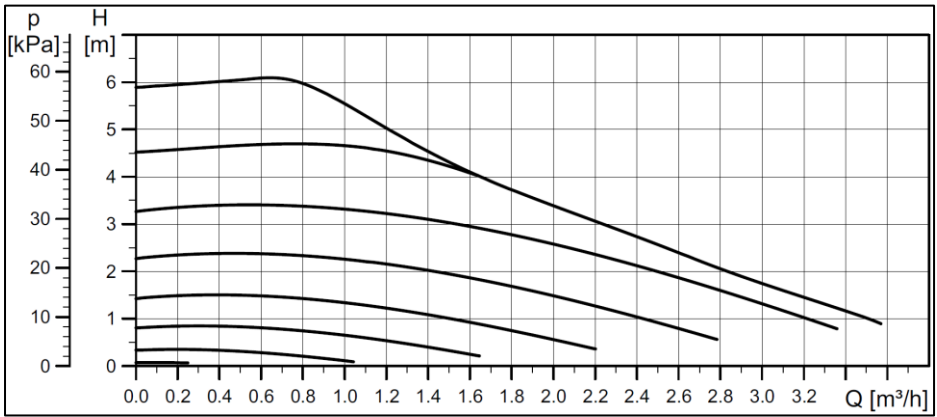

Figure 22

## 15- INSTALLATION TEMPLATE

### 15.1 HM Model

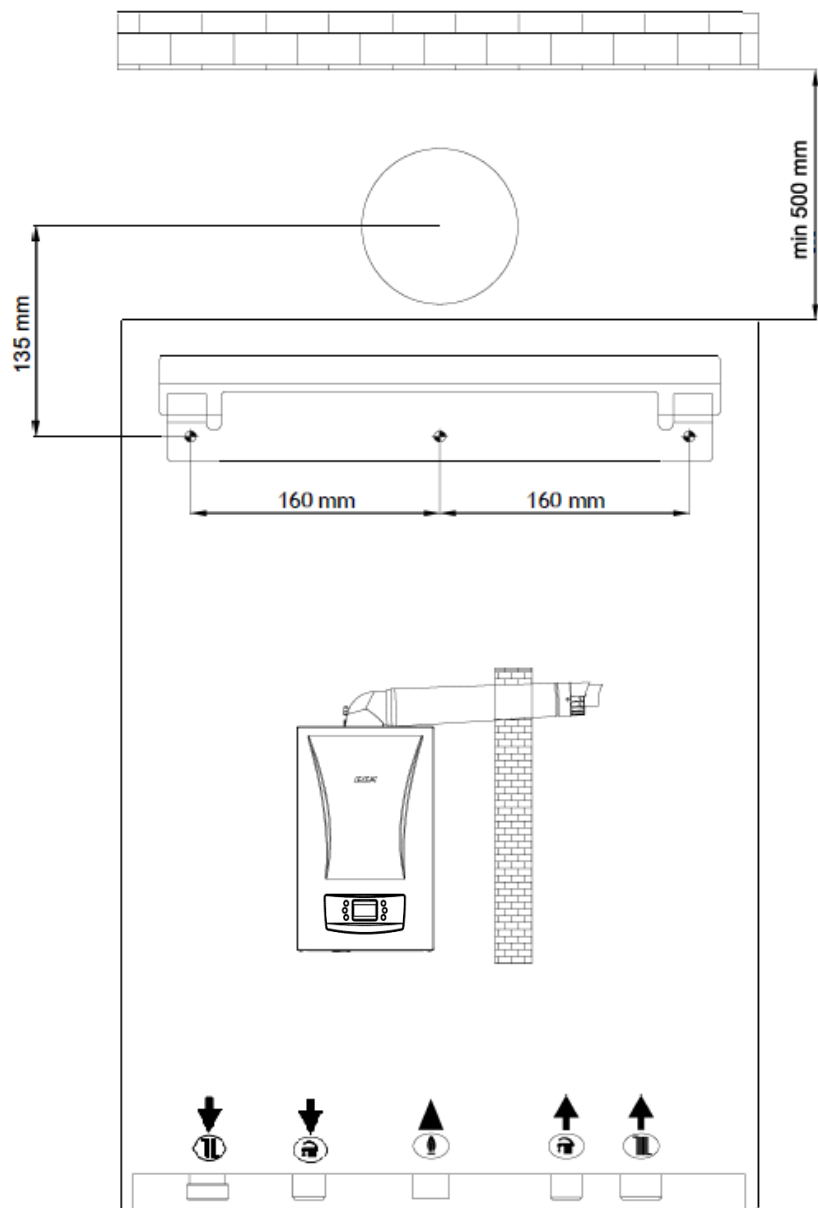

Figure 23

## 15.2 HCH Model

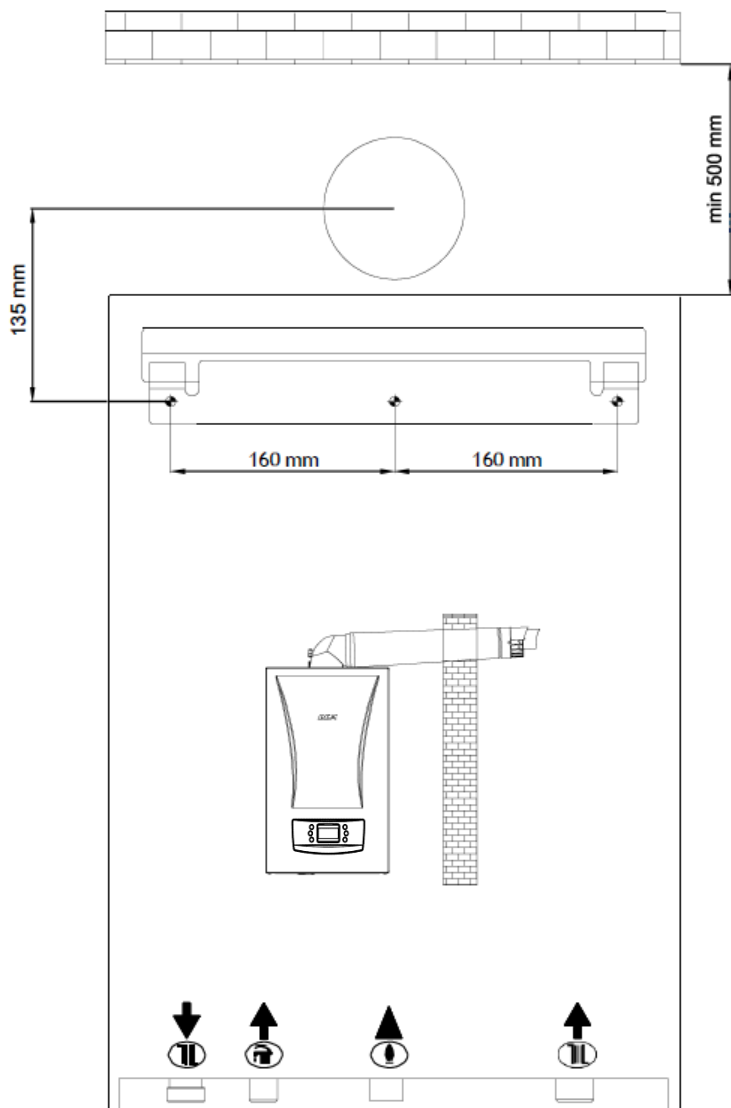

Figure 24



### 15.3 HST Model

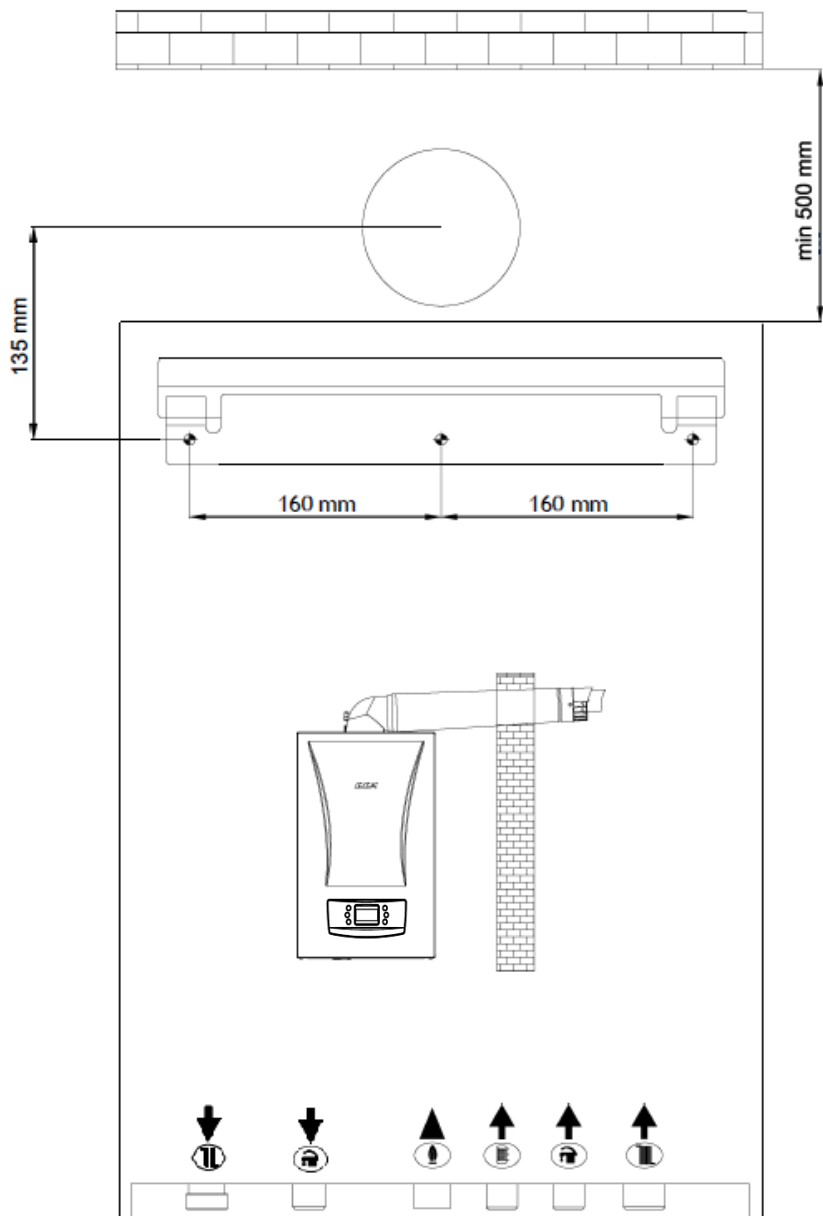

Figure 25

## 16- ERP MANUAL

### PRODUCT FICHES AND PACKAGE LABEL CALCULATIONS

#### 16.1. Product Fiches

Product fiche for combination boilers as required by EU regulations No 811/2013

Citius Premix Combi ERP		Unit	24 kW HM/HCH/HST Model	20 kW HM/HCH/HST Model	14 kW HM/HCH/HST Model
Supplier's Name or Trademark			E.C.A.	E.C.A.	E.C.A.
Supplier's Model Identifier			Citius Premix 24	Citius Premix 20	Citius Premix 14
Space Heating-Temperature Application			Medium	Medium	Medium
Efficiency Class	Seasonal Space heating		A	A	A
	Water heating *		A	A	A
Water heating load profile			XL	XL	XL
Rated heat output ( $P_{rated}$ )		kW	24,5	20,2	14,1
Annual energy consumption	Seasonal space heating	kWh	13226	11210	8988
		GJ	47,6	40,4	32,4
Annual electric consumption*	Domestic water heating	kWh	44	44	44
Annual fuel consumption*		GJ	17,1	17,1	17,1
Energy efficiency	Seasonal space heating	%	92,2	92	92
	Water heating *	%	85	85	85
Sound Power Level $L_{wa}$ Indoors		dB	52	52	52
Specific precautions for assembly, installation and maintenance			All specific precautions for installation, assembly and maintenance are described in the installation and service manual.	All specific precautions for installation, assembly and maintenance are described in the installation and service manual.	All specific precautions for installation, assembly and maintenance are described in the installation and service manual.

Table 6

\* Domestic water values are not applicable for HCH and HST models.

## 16.2. Package Fiche For Boilers Indicating The Space Heating Energy Efficiency Of The Package

### 16.2.1. Package Fiche-Boilers

#### Seasonal Space Heating Energy Efficiency of Boiler

"I": The value of the seasonal space heating energy efficiency of the preferential space heater, expressed in %.

①

I

%

#### Temperature Control

(Room Thermostat – Outdoor Sensor)  
From fiche of temperature control

Class I = 1% Class II = 2% Class III = 1,5%  
Class IV = 2% Class V = 3% Class VI = 4%  
Class VII = 3,5% Class VII = 5%

②

+

%

#### Supplementary boiler

From fiche of boiler

③

-
T
x 0,1
= ±

%

#### Solar Contribution

From fiche of solar device

Collector size (in m<sup>2</sup>)

Tank Volume (in m<sup>3</sup>)

Collector Efficiency (in %)

Tank rating  
A\*=0,95, A=0,91,  
B=0,86, C=0,83,  
D - G =0,81

("III" x

+

"IV" x

) x 0,9 x (

/ 100 x

= +

④ %

"III" : The value of the mathematical expression : 294/(11.Prated), whereby 'Prated' is related to the preferential space heater.

"IV" : The value of the mathematical expression : 115/(11.Prated), whereby 'Prated' is related to the preferential space heater.

(1) If tank rating is above A, use 0.95

#### Supplementary Heat Pump

From fiche of heat pump

Seasonal Space Heating Energy Efficiency (in %)

-

"I"

x

"II"

= +

⑤ %

"II" : The factor for weighting the heat output of preferential and supplementary heaters of a package as set out in the following table.

#### Solar Contribution And Supplementary Heat Pump

Select Smaller Value

0,5 x

④

or 0,5 x

⑤

= -

⑥

%

#### Seasonal Space Heating Energy Efficiency Class Of Package

⑦

-

%

#### Seasonal space heating energy efficiency class of package

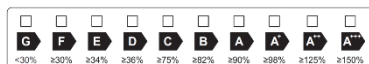

The energy efficiency of the package of products provided for in this fiche may not correspond to its actual energy efficiency once installed in a building, as this efficiency is influenced by further factors such as heat loss in the distribution system and the dimensioning of the products in relation to building size and characteristics.

### Water Heating Energy Efficiency Of Combination Heater

Declared load profile :  - "1"  %

### Solar Contribution

From fiche of solar device  $(1.1 \times 'I' - 10\%) \times 'II' - 'III'$  - 'I' =  %

### Water Heating Energy Efficiency Of Package Under Average Climate

%

### Water Heating Energy Efficiency Class Of Package Under Average Climate

	G	F	E	D	C	B	A	A'	A''	A'''
<input type="checkbox"/> M	<27%	≥27%	≥30%	≥33%	≥36%	≥39%	≥65%	≥100%	≥130%	≥163%
<input type="checkbox"/> L	<27%	≥27%	≥30%	≥34%	≥37%	≥50%	≥75%	≥115%	≥150%	≥188%
<input type="checkbox"/> XL	<27%	≥27%	≥30%	≥35%	≥38%	≥55%	≥80%	≥123%	≥160%	≥200%
<input type="checkbox"/> XXL	<28%	≥28%	≥32%	≥36%	≥40%	≥60%	≥85%	≥131%	≥170%	≥213%

### Water Heating Energy Efficiency Under Colder And Warmer Climate Conditions

Cold :  - 0,2 x  =  %

Warm :  - 0,2 x  =  %

The energy efficiency of the package of products provided for in this fiche may not correspond to its actual energy efficiency once installed in a building, as this efficiency is influenced by further factors such as heat loss in the distribution system and the dimensioning of the products in relation to building size and characteristics.

'I' The value of the water heating energy efficiency of the combination heater, expressed in %.

'II' The value of the mathematical expression  $(220 \cdot Q_{ref})/Q_{onsole}$ , where  $Q_{ref}$  is taken from Regulation EU 811/2013, Annex VII Table15 and  $Q_{onsole}$  from the product fiche of the solar device for the declared load profile M, L, XL or XXL of the combination heater.

'III' The value of the mathematical expression  $(Q_{aux} \cdot 2,5)/(220 \cdot Q_{ref})$ , expressed in %, where  $Q_{aux}$  is taken from the product fiche of the solar device and  $Q_{ref}$  from Regulation EU 811/2013, Annex VII Table 15 for the declared load profile M, L, XL or XXL.

### Boiler And Supplementary Heat Pump Installed With Low Temperature Heat Emitters At 35°C

From fiche of heat pump  <sup>7</sup> + ( 50 x "II" ) =  %

### Weighting of Boilers

Psup / (Prated+Psup) <sup>(1)(2)</sup>	II, package without hot water storage tank	II, package with hot water storage tank
0	0	0
0.1	0.3	0.37
0.2	0.55	0.70
0.3	0.75	0.85
0.4	0.85	0.94
0.5	0.95	0.98
0.6	0.98	1
0.7	1	1

(1) The intermediate values are calculated by linear interpolation between in two adjacent values.

(2) Prated is related to the preferential space heater or combination heater.

## 17- DECLARATION OF CONFORMITY



EMAS MAKİNE SANAYİ A.Ş.

### AT UYGUNLUK BEYANI DECLARATION OF CONFORMITY

ÜRETİCİ : EMAS MAKİNE SANAYİ A.Ş.  
MANUFACTURER : Organize Sanayi Bölgesi 3.Kısım Mustafa Kemal Bulvarı No: 13 45030  
MANİSA Tel: +90 236 213 00 21 Faks: +90 236 213 08 59  
satış@emas.com.tr

ONAYLANMIŞ KURULUŞ : 0085-DVGW CERT GmbH  
NOTIFIED BODY : DBI Gastecnologisches Institut GmbH Freiberg

ÜRÜN ADI : E.C.A. Yoğuşmalı Kombiler  
PRODUCT NAME : E.C.A. Condensing Gas Boiler

İNCELENMİŞ TİPLER : Citius Premix 24/20/14 kW HM/HCH/HST  
TYPE EXAMINATION

2016/426/AB GAR Gaz Yakan Cihazlar Regülasyonu / 2016/426/EU Regulation on Appliances Burning Gaseous Fuels, EN 15502-2-1

2014/35/AB Belirli Gerilim Sınırları İçin Tasarlanan Elektrikli Ekipman İle İlgili Yönetmelik / 2014/35/EU Low Voltage Directive

EN60335-1, EN 60335-2-102

2014/30/AB Elektromanyetik Uyumluluk Yönetmeliği / 2014/30/EU EMC Directive

EN 55014-1, EN 55014-2, EN 61003-2, EN 61003-3, EN 61000-4-2, EN 61000-4-3, EN 61000-4-4, EN 61000-4-5, EN 61000-4-6, EN 61000-4-11

92/42/AT Sıvı Ve Gaz Yakıtlı Yeni Sıcak Su Kazanlarının Verimlilik Gereklere Dair Yönetmelik /

92/42/EEC Directive on efficiency requirements for new hot-water boilers fired with liquid or gaseous fuels

Aşağıda imzası bulunan şirketimiz yukarıda adı, tipi ve modeli belirlenen cihazları, ekte yer alan B/19/08/3060 EU numaralı rapor dahilinde ilgili standartlara, (92/42/AT) Gaz Yakan Cihazlar ve AT Sıcak Su Kazanlarının Verimlilik Yönetmeliklerine uygun olarak tasarlayıp ürettiği beyan eder.

The undersigned company certifies under its sole responsibility that the item of equipment specified above has been designed, manufactured, inspected and tested as required by the relevant provisions of the EC Gas Appliances Directive and the EC Boiler Efficiency Directive based on the enclosed pages of the EC type examination report (CE Pin number: CE-0085CT0347)

Yetkili olmayan kişiler tarafından yapılan değişiklikler ya da uygun olmayan kullanım şekilleri bu beyanı geçersiz kılar.

Any unauthorised changes to the supplied products and/or any improper use invalidates this declaration of conformity.

Üretici Adına İmzalayanlar / Signed On Behalf Of The Manufacturer :

İsim (Name) : Ali YURTERİ  
Görevi (Position) : Kalite Sistemleri Müdürü  
Quality Assurance Manager

Emek DOĞAN  
Genel Müdür Yardımcısı  
Vice General Manager

Yer (Place) : Manisa  
Tarih (Date) : 04.11.2019

## SELLER COMPANY

Title : ..... Invoice Date and No : .....  
Address : ..... Delivery Date and Place : .....  
Phone/Fax : ..... Date, Signature and Seal : .....  
.....

## PRODUCT'S

Type : Combi Boiler with gas fuel Serial No : .....  
Brand : E.C.A. Delivery Date and Place : .....  
Model : ..... Maximum Repair Period : 20 Business Days  
..... Warranty Period : 3 Years

## AUTHORIZED SERVICE

Title : ..... Assembly Date : .....  
Address : ..... Date, Signature and Seal : .....  
Phone : .....  
Fax : .....

### ***FREE INITIAL OPERATION COUPON***

Type : Combi Boiler with Gas Fuel  
Brand : E.C.A.  
Model : .....  
Serial No : .....  
Assembly Date : .....  
Authorized Service's Title : .....  
Date : .....  
Service Voucher No : .....

## **PRODUCTION**

### **EMAS MAKİNA SANAYİ A.Ş.**

Organize Sanayi Bölgesi 3.Kısım  
Mustafa Kemal Bulvarı No: 13  
45030 MANİSA  
Phone : +90 236 213 00 21  
Fax : +90 236 213 08 59  
Email : emas@emas.com.tr  
www.emas.com.tr

## **SALES**

### **EMAS MAKİNA SANAYİ A.Ş.**

Yalı Mah. Ziya Gökalp Cd. No: 3 34844  
Maltepe / İSTANBUL  
Phone : +90 216 442 34 41  
Fax : +90 216 442 39 96  
Email : satis@emas.com.tr  
www.emas.com.tr

## **SERVICE**

### **EMAR A.Ş. SERVİS MÜDÜRLÜĞÜ**

Yalı Mah. Ziya Gökalp Cd. No: 3 34844  
Maltepe / İSTANBUL  
Phone : +90 216 458 45 00 (pbx)  
Fax : +90 216 305 65 43  
Email : emar@emarservis.com.tr  
www.emarservis.com.tr

**E.C.A. Call Center: 444 0 322**

**EMAS A.Ş. and EMAR A.Ş.  
ARE INSTITUTIONS OF ELGINKAN GROUP**



7006991561.1.0